



# Red Hat Data Grid 8.3

## Configuring Data Grid Caches

Configure Data Grid caches to customize your deployment



## Red Hat Data Grid 8.3 Configuring Data Grid Caches

---

Configure Data Grid caches to customize your deployment

## Legal Notice

Copyright © 2023 Red Hat, Inc.

The text of and illustrations in this document are licensed by Red Hat under a Creative Commons Attribution–Share Alike 3.0 Unported license ("CC-BY-SA"). An explanation of CC-BY-SA is available at

<http://creativecommons.org/licenses/by-sa/3.0/>

. In accordance with CC-BY-SA, if you distribute this document or an adaptation of it, you must provide the URL for the original version.

Red Hat, as the licensor of this document, waives the right to enforce, and agrees not to assert, Section 4d of CC-BY-SA to the fullest extent permitted by applicable law.

Red Hat, Red Hat Enterprise Linux, the Shadowman logo, the Red Hat logo, JBoss, OpenShift, Fedora, the Infinity logo, and RHCE are trademarks of Red Hat, Inc., registered in the United States and other countries.

Linux<sup>®</sup> is the registered trademark of Linus Torvalds in the United States and other countries.

Java<sup>®</sup> is a registered trademark of Oracle and/or its affiliates.

XFS<sup>®</sup> is a trademark of Silicon Graphics International Corp. or its subsidiaries in the United States and/or other countries.

MySQL<sup>®</sup> is a registered trademark of MySQL AB in the United States, the European Union and other countries.

Node.js<sup>®</sup> is an official trademark of Joyent. Red Hat is not formally related to or endorsed by the official Joyent Node.js open source or commercial project.

The OpenStack<sup>®</sup> Word Mark and OpenStack logo are either registered trademarks/service marks or trademarks/service marks of the OpenStack Foundation, in the United States and other countries and are used with the OpenStack Foundation's permission. We are not affiliated with, endorsed or sponsored by the OpenStack Foundation, or the OpenStack community.

All other trademarks are the property of their respective owners.

## Abstract

Configure Data Grid deployments to use features and capabilities that suit your business requirements.

## Table of Contents

<b>RED HAT DATA GRID</b> .....	<b>6</b>
<b>DATA GRID DOCUMENTATION</b> .....	<b>7</b>
<b>DATA GRID DOWNLOADS</b> .....	<b>8</b>
<b>MAKING OPEN SOURCE MORE INCLUSIVE</b> .....	<b>9</b>
<b>CHAPTER 1. DATA GRID CACHES</b> .....	<b>10</b>
1.1. CACHE API	10
1.2. CACHE MANAGERS	10
1.3. CACHE MODES	10
1.3.1. Comparison of cache modes	11
1.4. LOCAL CACHES	12
Local cache configuration	12
1.4.1. Simple caches	12
Simple cache configuration	13
<b>CHAPTER 2. CLUSTERED CACHES</b> .....	<b>14</b>
2.1. REPLICATED CACHES	14
2.2. DISTRIBUTED CACHES	15
2.2.1. Read consistency	16
2.2.2. Key ownership	17
Hashing configuration	18
2.2.3. Capacity factors	19
2.2.3.1. Zero capacity nodes	19
Zero capacity node configuration	19
2.2.4. Level one (L1) caches	20
L1 caching performance	20
L1 cache configuration	20
2.2.5. Server hinting	21
Server hinting configuration	21
2.2.6. Key affinity service	22
Lifecycle	23
Topology changes	23
2.2.7. Grouping API	23
Advanced API	25
2.3. INVALIDATION CACHES	25
2.4. SCATTERED CACHES	27
2.5. ASYNCHRONOUS REPLICATION	28
Asynchronous API	28
2.5.1. Return values with asynchronous replication	28
2.6. CONFIGURING INITIAL CLUSTER SIZE	29
Initial cluster size configuration	29
<b>CHAPTER 3. DATA GRID CACHE CONFIGURATION</b> .....	<b>31</b>
3.1. DECLARATIVE CACHE CONFIGURATION	31
3.1.1. Cache configuration	31
Distributed caches	32
Replicated caches	34
Multiple caches	35
3.2. ADDING CACHE TEMPLATES	38
Cache template example	38

3.2.1. Creating caches from templates	39
Cache configuration inherited from a template	39
3.2.2. Cache template inheritance	40
Template inheritance example	40
3.2.3. Cache template wildcards	41
Template wildcard example	41
3.2.4. Cache templates from multiple XML files	42
3.3. CREATING REMOTE CACHES	43
3.3.1. Default Cache Manager	43
Default Cache Manager configuration	44
3.3.2. Creating caches with Data Grid Console	45
3.3.3. Creating remote caches with the Data Grid CLI	45
3.3.4. Creating remote caches from Hot Rod clients	46
3.3.5. Creating remote caches with the REST API	47
3.4. CREATING EMBEDDED CACHES	47
3.4.1. Adding Data Grid to your project	47
3.4.2. Configuring embedded caches	47
<b>CHAPTER 4. ENABLING AND CONFIGURING DATA GRID STATISTICS AND JMX MONITORING</b> .....	<b>49</b>
4.1. CONFIGURING DATA GRID METRICS	49
Metrics configuration	49
4.2. REGISTERING JMX MBEANS	50
JMX configuration	50
4.2.1. Enabling JMX remote ports	51
4.2.2. Data Grid MBeans	52
4.2.3. Registering MBeans in custom MBean servers	52
JMX MBean server lookup configuration	53
<b>CHAPTER 5. CONFIGURING JVM MEMORY USAGE</b> .....	<b>54</b>
5.1. DEFAULT MEMORY CONFIGURATION	54
5.2. EVICTION AND EXPIRATION	54
5.3. EVICTION WITH DATA GRID CACHES	55
5.3.1. Eviction strategies	55
5.3.2. Configuring maximum count eviction	56
Maximum count eviction	56
5.3.3. Configuring maximum size eviction	57
Maximum size eviction	57
5.3.4. Manual eviction	58
5.3.5. Passivation with eviction	59
5.4. EXPIRATION WITH LIFESPAN AND MAXIMUM IDLE	60
5.4.1. How expiration works	61
5.4.2. Expiration reaper	61
5.4.3. Maximum idle and clustered caches	62
5.4.4. Configuring lifespan and maximum idle times for caches	62
Expiration for Data Grid caches	62
5.4.5. Configuring lifespan and maximum idle times per entry	63
5.5. JVM HEAP AND OFF-HEAP MEMORY	64
JVM heap memory	64
Off-heap memory	64
5.5.1. Off-heap data storage	65
5.5.2. Configuring off-heap memory	65
Off-heap storage	65
<b>CHAPTER 6. CONFIGURING PERSISTENT STORAGE</b> .....	<b>67</b>

---

6.1. PASSIVATION	67
6.1.1. How passivation works	67
6.2. WRITE-THROUGH CACHE STORES	68
Write-through configuration	69
6.3. WRITE-BEHIND CACHE STORES	69
Write-behind configuration	69
Failing silently	71
6.4. SEGMENTED CACHE STORES	71
6.5. SHARED CACHE STORES	71
6.6. TRANSACTIONS WITH PERSISTENT CACHE STORES	72
6.7. GLOBAL PERSISTENT LOCATION	72
Remote caches	72
Embedded caches	73
6.7.1. Configuring the global persistent location	73
Global persistent location configuration	74
6.8. FILE-BASED CACHE STORES	75
Soft-Index File Stores	75
Single File Cache Stores	76
6.8.1. Configuring file-based cache stores	76
File-based cache store configuration	77
6.8.2. Configuring single file cache stores	78
Single file cache store configuration	78
6.9. JDBC CONNECTION FACTORIES	79
Connection pools	79
Managed datasources	80
Simple connections	81
6.9.1. Configuring managed datasources	82
Managed datasource configuration	83
6.9.1.1. Configuring caches with JNDI names	85
JNDI name in cache configuration	85
6.9.1.2. Connection pool tuning properties	87
6.9.2. Configuring JDBC connection pools with Agroal properties	87
6.10. SQL CACHE STORES	89
6.10.1. Data types for keys and values	89
6.10.1.1. Composite keys and values	90
Composite values	90
Composite keys and values	90
6.10.1.2. Embedded keys	91
6.10.1.3. SQL types to Protobuf types	91
6.10.2. Loading Data Grid caches from database tables	92
SQL table store configuration	93
6.10.3. Using SQL queries to load data and perform operations	95
6.10.3.1. SQL query store configuration	97
SQL statements	97
Protobuf schemas	97
Cache configuration	98
6.10.4. SQL cache store troubleshooting	100
6.11. JDBC STRING-BASED CACHE STORES	101
6.11.1. Configuring JDBC string-based cache stores	101
JDBC string-based cache store configuration	102
6.12. ROCKSDB CACHE STORES	104
RocksDB cache store configuration	106
6.13. REMOTE CACHE STORES	107

---

Remote cache store configuration	107
6.14. JPA CACHE STORES	109
JPA cache store configuration	109
Configuration parameters	110
6.14.1. JPA cache store example	110
6.15. CLUSTER CACHE LOADERS	112
Cluster cache loader configuration	112
6.16. CREATING CUSTOM CACHE STORE IMPLEMENTATIONS	113
6.16.1. Data Grid Persistence SPI	113
6.16.2. Creating cache stores	114
6.16.3. Examples of custom cache store configuration	114
6.16.4. Deploying custom cache stores	115
6.17. MIGRATING DATA BETWEEN CACHE STORES	115
6.17.1. Cache store migrator	115
6.17.2. Getting the cache store migrator	116
6.17.3. Configuring the cache store migrator	117
6.17.3.1. Configuration properties for the cache store migrator	117
6.17.4. Migrating Data Grid cache stores	121
<b>CHAPTER 7. CONFIGURING DATA GRID TO HANDLE NETWORK PARTITIONS</b> .....	<b>123</b>
7.1. SPLIT CLUSTERS AND NETWORK PARTITIONS	123
7.1.1. Data consistency in a split cluster	123
7.2. CACHE AVAILABILITY AND DEGRADED MODE	124
7.2.1. Degraded cache recovery example	125
7.2.2. Verifying cache availability during network partitions	125
7.2.3. Making caches available	126
7.3. CONFIGURING PARTITION HANDLING	127
Partition handling configuration	127
7.4. PARTITION HANDLING STRATEGIES	128
7.5. MERGE POLICIES	129
7.6. CONFIGURING CUSTOM MERGE POLICIES	129
Custom merge policy configuration	130
7.7. MANUALLY MERGING PARTITIONS IN EMBEDDED CACHES	131
<b>CHAPTER 8. CONFIGURING USER ROLES AND PERMISSIONS</b> .....	<b>133</b>
8.1. SECURITY AUTHORIZATION	133
8.1.1. User roles and permissions	133
8.1.2. Permissions	134
8.1.2.1. Cache Manager permissions	134
8.1.2.2. Cache permissions	135
8.1.3. Role mappers	136
8.1.3.1. Cluster role mappers	136
8.1.3.2. Identity role mappers	136
8.1.3.3. CommonName role mappers	137
8.1.3.4. Custom role mappers	137
8.2. ACCESS CONTROL LIST (ACL) CACHE	137
8.3. CUSTOMIZING ROLES AND PERMISSIONS	138
Custom roles and permissions configuration	138
8.4. CONFIGURING CACHES WITH SECURITY AUTHORIZATION	140
Authorization configuration	140
Custom roles and permissions	141
8.5. DISABLING SECURITY AUTHORIZATION	141





## RED HAT DATA GRID

Data Grid is a high-performance, distributed in-memory data store.

### **Schemaless data structure**

Flexibility to store different objects as key-value pairs.

### **Grid-based data storage**

Designed to distribute and replicate data across clusters.

### **Elastic scaling**

Dynamically adjust the number of nodes to meet demand without service disruption.

### **Data interoperability**

Store, retrieve, and query data in the grid from different endpoints.

# DATA GRID DOCUMENTATION

Documentation for Data Grid is available on the Red Hat customer portal.

- [Data Grid 8.3 Documentation](#)
- [Data Grid 8.3 Component Details](#)
- [Supported Configurations for Data Grid 8.3](#)
- [Data Grid 8 Feature Support](#)
- [Data Grid Deprecated Features and Functionality](#)

## DATA GRID DOWNLOADS

Access the [Data Grid Software Downloads](#) on the Red Hat customer portal.



### NOTE

You must have a Red Hat account to access and download Data Grid software.

## MAKING OPEN SOURCE MORE INCLUSIVE

Red Hat is committed to replacing problematic language in our code, documentation, and web properties. We are beginning with these four terms: master, slave, blacklist, and whitelist. Because of the enormity of this endeavor, these changes will be implemented gradually over several upcoming releases. For more details, see [our CTO Chris Wright's message](#).

# CHAPTER 1. DATA GRID CACHES

Data Grid caches provide flexible, in-memory data stores that you can configure to suit use cases such as:

- Boosting application performance with high-speed local caches.
- Optimizing databases by decreasing the volume of write operations.
- Providing resiliency and durability for consistent data across clusters.

## 1.1. CACHE API

**Cache<K,V>** is the central interface for Data Grid and extends **java.util.concurrent.ConcurrentMap**.

Cache entries are highly concurrent data structures in **key:value** format that support a wide and configurable range of data types, from simple strings to much more complex objects.

## 1.2. CACHE MANAGERS

The **CacheManager** API is the starting point for interacting with Data Grid caches. Cache managers control cache lifecycle; creating, modifying, and deleting cache instances.

Data Grid provides two **CacheManager** implementations:

### **EmbeddedCacheManager**

Entry point for caches when running Data Grid inside the same Java Virtual Machine (JVM) as the client application.

### **RemoteCacheManager**

Entry point for caches when running Data Grid Server in its own JVM. When you instantiate a **RemoteCacheManager** it establishes a persistent TCP connection to Data Grid Server through the Hot Rod endpoint.



### NOTE

Both embedded and remote **CacheManager** implementations share some methods and properties. However, semantic differences do exist between **EmbeddedCacheManager** and **RemoteCacheManager**.

## 1.3. CACHE MODES

### TIP

Data Grid cache managers can create and control multiple caches that use different modes. For example, you can use the same cache manager for local caches, distributed caches, and caches with invalidation mode.

### Local

Data Grid runs as a single node and never replicates read or write operations on cache entries.

### Replicated

Data Grid replicates all cache entries on all nodes in a cluster and performs local read operations only.

### Distributed

Data Grid replicates cache entries on a subset of nodes in a cluster and assigns entries to fixed owner nodes.

Data Grid requests read operations from owner nodes to ensure it returns the correct value.

### Invalidation

Data Grid evicts stale data from all nodes whenever operations modify entries in the cache. Data Grid performs local read operations only.

### Scattered

Data Grid stores cache entries across a subset of nodes.

By default Data Grid assigns a primary owner and a backup owner to each cache entry in scattered caches.

Data Grid assigns primary owners in the same way as with distributed caches, while backup owners are always the nodes that initiate the write operations.

Data Grid requests read operations from at least one owner node to ensure it returns the correct value.

## 1.3.1. Comparison of cache modes

The cache mode that you should choose depends on the qualities and guarantees you need for your data.

The following table summarizes the primary differences between cache modes:

Cache mode	Clustered?	Read performance	Write performance	Capacity	Availability	Capabilities
Local	No	High (local)	High (local)	Single node	Single node	Complete
Simple	No	Highest (local)	Highest (local)	Single node	Single node	Partial: no transactions, persistence, or indexing.
Invalidation	Yes	High (local)	Low (all nodes, no data)	Single node	Single node	Partial: no indexing.
Replicated	Yes	High (local)	Lowest (all nodes)	Smallest node	All nodes	Complete
Distributed	Yes	Medium (owners)	Medium (owner nodes)	Sum of all nodes capacity divided by the number of owners.	Owner nodes	Complete

Cache mode	Clustered?	Read performance	Write performance	Capacity	Availability	Capabilities
Scattered	Yes	Medium (primary)	Higher (single RPC)	Sum of all nodes capacity divided by 2.	Owner nodes	Partial: no transactions.

## 1.4. LOCAL CACHES

Data Grid offers a local cache mode that is similar to a **ConcurrentHashMap**.

Caches offer more capabilities than simple maps, including write-through and write-behind to persistent storage as well as management capabilities such as eviction and expiration.

The Data Grid **Cache** API extends the **ConcurrentMap** API in Java, making it easy to migrate from a map to a Data Grid cache.

### Local cache configuration

#### XML

```
<local-cache name="mycache"
  statistics="true">
  <encoding media-type="application/x-protostream"/>
</local-cache>
```

#### JSON

```
{
  "local-cache": {
    "name": "mycache",
    "statistics": "true",
    "encoding": {
      "media-type": "application/x-protostream"
    }
  }
}
```

#### YAML

```
localCache:
  name: "mycache"
  statistics: "true"
  encoding:
    mediaType: "application/x-protostream"
```

### 1.4.1. Simple caches

A simple cache is a type of local cache that disables support for the following capabilities:



- Transactions and invocation batching
- Persistent storage
- Custom interceptors
- Indexing
- Transcoding

However, you can use other Data Grid capabilities with simple caches such as expiration, eviction, statistics, and security features. If you configure a capability that is not compatible with a simple cache, Data Grid throws an exception.

### Simple cache configuration

#### XML

```
<local-cache simple-cache="true" />
```

#### JSON

```
{  
  "local-cache" : {  
    "simple-cache" : "true"  
  }  
}
```

#### YAML

```
localCache:  
  simpleCache: "true"
```

## CHAPTER 2. CLUSTERED CACHES

You can create embedded and remote caches on Data Grid clusters that replicate data across nodes.

### 2.1. REPLICATED CACHES

Data Grid replicates all entries in the cache to all nodes in the cluster. Each node can perform read operations locally.

Replicated caches provide a quick and easy way to share state across a cluster, but is suitable for clusters of less than ten nodes. Because the number of replication requests scales linearly with the number of nodes in the cluster, using replicated caches with larger clusters reduces performance. However you can use UDP multicasting for replication requests to improve performance.

Each key has a primary owner, which serializes data container updates in order to provide consistency.

Figure 2.1. Replicated cache

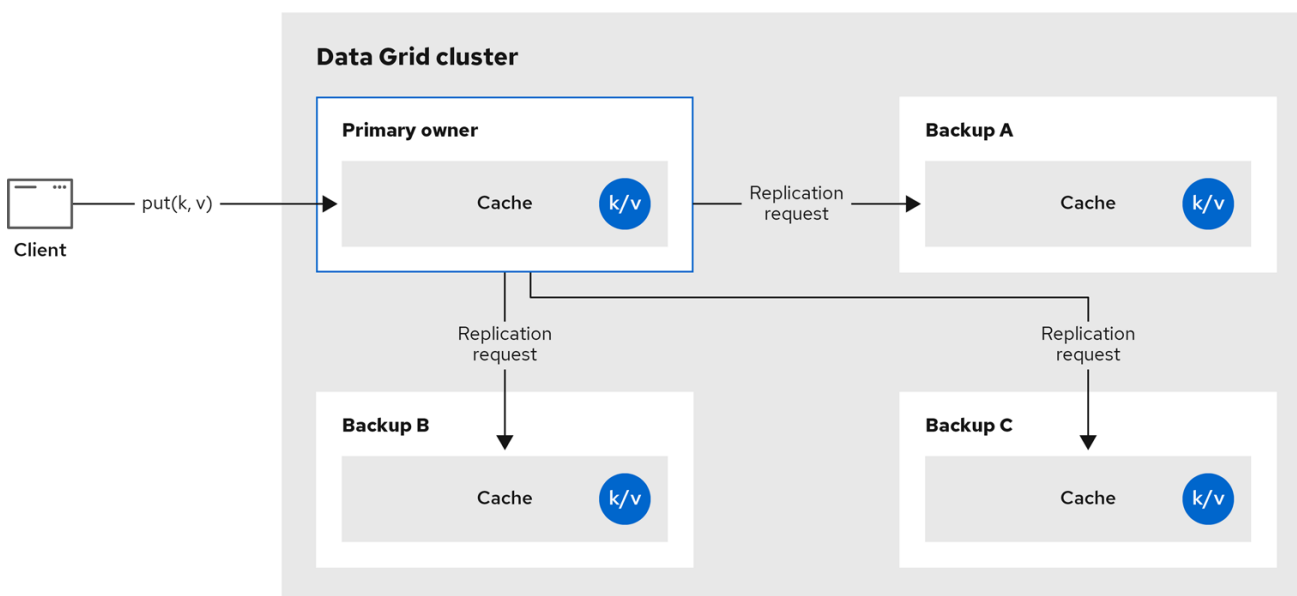

184\_Data\_Grid\_0921

#### Synchronous or asynchronous replication

- Synchronous replication blocks the caller (e.g. on a `cache.put(key, value)`) until the modifications have been replicated successfully to all the nodes in the cluster.
- Asynchronous replication performs replication in the background, and write operations return immediately. Asynchronous replication is not recommended, because communication errors, or errors that happen on remote nodes are not reported to the caller.

#### Transactions

If transactions are enabled, write operations are not replicated through the primary owner.

With pessimistic locking, each write triggers a lock message, which is broadcast to all the nodes. During transaction commit, the originator broadcasts a one-phase prepare message and an unlock message (optional). Either the one-phase prepare or the unlock message is fire-and-forget.

With optimistic locking, the originator broadcasts a prepare message, a commit message, and an unlock message (optional). Again, either the one-phase prepare or the unlock message is fire-and-forget.

## 2.2. DISTRIBUTED CACHES

Data Grid attempts to keep a fixed number of copies of any entry in the cache, configured as **numOwners**. This allows distributed caches to scale linearly, storing more data as nodes are added to the cluster.

As nodes join and leave the cluster, there will be times when a key has more or less than **numOwners** copies. In particular, if **numOwners** nodes leave in quick succession, some entries will be lost, so we say that a distributed cache tolerates **numOwners - 1** node failures.

The number of copies represents a trade-off between performance and durability of data. The more copies you maintain, the lower performance will be, but also the lower the risk of losing data due to server or network failures.

Data Grid splits the owners of a key into one **primary owner**, which coordinates writes to the key, and zero or more **backup owners**.

The following diagram shows a write operation that a client sends to a backup owner. In this case the backup node forwards the write to the primary owner, which then replicates the write to the backup.

Figure 2.2. Cluster replication

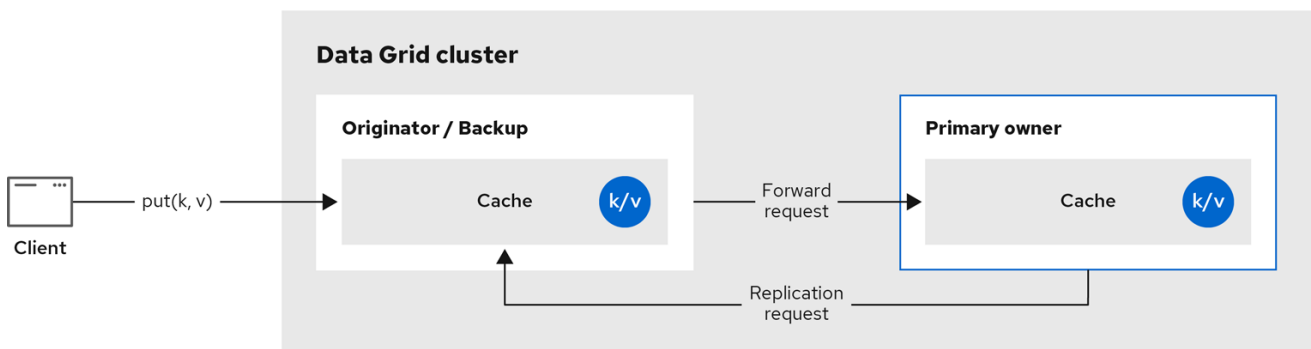

184\_Data\_Grid\_0921

Figure 2.3. Distributed cache

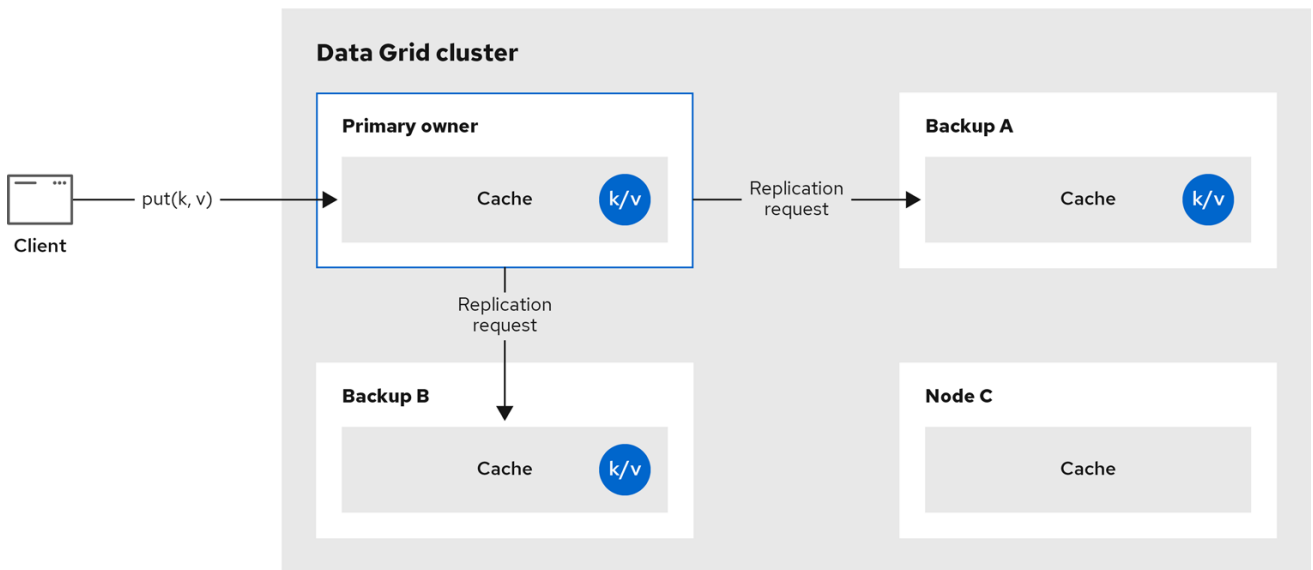

184\_Data\_Grid\_0921

## Read operations

Read operations request the value from the primary owner. If the primary owner does not respond in a reasonable amount of time, Data Grid requests the value from the backup owners as well.

A read operation may require **0** messages if the key is present in the local cache, or up to **2 \* numOwners** messages if all the owners are slow.

## Write operations

Write operations result in at most **2 \* numOwners** messages. One message from the originator to the primary owner and **numOwners - 1** messages from the primary to the backup nodes along with the corresponding acknowledgment messages.

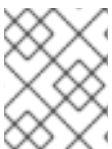

### NOTE

Cache topology changes may cause retries and additional messages for both read and write operations.

## Synchronous or asynchronous replication

Asynchronous replication is not recommended because it can lose updates. In addition to losing updates, asynchronous distributed caches can also see a stale value when a thread writes to a key and then immediately reads the same key.

## Transactions

Transactional distributed caches send lock/prepare/commit/unlock messages to the affected nodes only, meaning all nodes that own at least one key affected by the transaction. As an optimization, if the transaction writes to a single key and the originator is the primary owner of the key, lock messages are not replicated.

### 2.2.1. Read consistency

Even with synchronous replication, distributed caches are not linearizable. For transactional caches, they do not support serialization/snapshot isolation.

For example, a thread is carrying out a single put request:

```
cache.get(k) -> v1
cache.put(k, v2)
cache.get(k) -> v2
```

But another thread might see the values in a different order:

```
cache.get(k) -> v2
cache.get(k) -> v1
```

The reason is that read can return the value from any owner, depending on how fast the primary owner replies. The write is not atomic across all the owners. In fact, the primary commits the update only after it receives a confirmation from the backup. While the primary is waiting for the confirmation message from the backup, reads from the backup will see the new value, but reads from the primary will see the old one.

### 2.2.2. Key ownership

Distributed caches split entries into a fixed number of segments and assign each segment to a list of owner nodes. Replicated caches do the same, with the exception that every node is an owner.

The first node in the list of owners is the **primary owner**. The other nodes in the list are **backup owners**. When the cache topology changes, because a node joins or leaves the cluster, the segment ownership table is broadcast to every node. This allows nodes to locate keys without making multicast requests or maintaining metadata for each key.

The **numSegments** property configures the number of segments available. However, the number of segments cannot change unless the cluster is restarted.

Likewise the key-to-segment mapping cannot change. Keys must always map to the same segments regardless of cluster topology changes. It is important that the key-to-segment mapping evenly distributes the number of segments allocated to each node while minimizing the number of segments that must move when the cluster topology changes.

Consistent hash factory implementation	Description
<b>SyncConsistentHashFactory</b>	<p>Uses an algorithm based on <a href="#">consistent hashing</a>. Selected by default when server hinting is disabled.</p> <p>This implementation always assigns keys to the same nodes in every cache as long as the cluster is symmetric. In other words, all caches run on all nodes. This implementation does have some negative points in that the load distribution is slightly uneven. It also moves more segments than strictly necessary on a join or leave.</p>

Consistent hash factory implementation	Description
<b>TopologyAwareSyncConsistentHashFactory</b>	Equivalent to <b>SyncConsistentHashFactory</b> but used with server hinting to distribute data across the topology so that backed up copies of data are stored on different nodes in the topology than the primary owners. This is the default consistent hashing implementation with server hinting.
<b>DefaultConsistentHashFactory</b>	Achieves a more even distribution than <b>SyncConsistentHashFactory</b> , but with one disadvantage. The order in which nodes join the cluster determines which nodes own which segments. As a result, keys might be assigned to different nodes in different caches.
<b>TopologyAwareConsistentHashFactory</b>	Equivalent to <b>DefaultConsistentHashFactory</b> but used with server hinting to distribute data across the topology so that backed up copies of data are stored on different nodes in the topology than the primary owners.
<b>ReplicatedConsistentHashFactory</b>	Used internally to implement replicated caches. You should never explicitly select this algorithm in a distributed cache.

### Hashing configuration

You can configure **ConsistentHashFactory** implementations, including custom ones, with embedded caches only.

### XML

```
<distributed-cache name="distributedCache"
  owners="2"
  segments="100"
  capacity-factor="2" />
```

### ConfigurationBuilder

```
Configuration c = new ConfigurationBuilder()
  .clustering()
  .cacheMode(CacheMode.DIST_SYNC)
  .hash()
  .numOwners(2)
  .numSegments(100)
  .capacityFactor(2)
  .build();
```

### Additional resources

- [KeyPartitioner](#)

### 2.2.3. Capacity factors

Capacity factors allocate the number of segments based on resources available to each node in the cluster.

The capacity factor for a node applies to segments for which that node is both the primary owner and backup owner. In other words, the capacity factor specifies is the total capacity that a node has in comparison to other nodes in the cluster.

The default value is **1** which means that all nodes in the cluster have an equal capacity and Data Grid allocates the same number of segments to all nodes in the cluster.

However, if nodes have different amounts of memory available to them, you can configure the capacity factor so that the Data Grid hashing algorithm assigns each node a number of segments weighted by its capacity.

The value for the capacity factor configuration must be a positive number and can be a fraction such as 1.5. You can also configure a capacity factor of **0** but is recommended only for nodes that join the cluster temporarily and should use the zero capacity configuration instead.

#### 2.2.3.1. Zero capacity nodes

You can configure nodes where the capacity factor is **0** for every cache, user defined caches, and internal caches. When defining a zero capacity node, the node does not hold any data.

#### Zero capacity node configuration

##### XML

```
<infinispan>
  <cache-container zero-capacity-node="true" />
</infinispan>
```

##### JSON

```
{
  "infinispan" : {
    "cache-container" : {
      "zero-capacity-node" : "true"
    }
  }
}
```

##### YAML

```
infinispan:
  cacheContainer:
    zeroCapacityNode: "true"
```

#### ConfigurationBuilder

```
new GlobalConfigurationBuilder().zeroCapacityNode(true);
```

## 2.2.4. Level one (L1) caches

Data Grid nodes create local replicas when they retrieve entries from another node in the cluster. L1 caches avoid repeatedly looking up entries on primary owner nodes and adds performance.

The following diagram illustrates how L1 caches work:

Figure 2.4. L1 cache

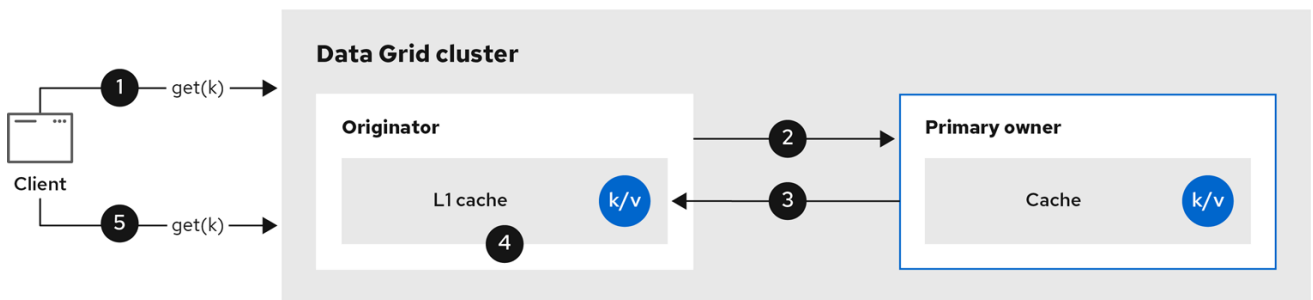

184\_Data\_Grid\_0921

In the "L1 cache" diagram:

1. A client invokes **cache.get()** to read an entry for which another node in the cluster is the primary owner.
2. The originator node forwards the read operation to the primary owner.
3. The primary owner returns the key/value entry.
4. The originator node creates a local copy.
5. Subsequent **cache.get()** invocations return the local entry instead of forwarding to the primary owner.

### L1 caching performance

Enabling L1 improves performance for read operations but requires primary owner nodes to broadcast invalidation messages when entries are modified. This ensures that Data Grid removes any out of date replicas across the cluster. However this also decreases performance of write operations and increases memory usage, reducing overall capacity of caches.

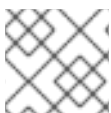

#### NOTE

Data Grid evicts and expires local replicas, or L1 entries, like any other cache entry.

### L1 cache configuration

#### XML

```
<distributed-cache l1-lifespan="5000"
    l1-cleanup-interval="60000">
</distributed-cache>
```



## JSON

```
{
  "distributed-cache": {
    "l1-lifespan": "5000",
    "l1-cleanup-interval": "60000"
  }
}
```

## YAML

```
distributedCache:
  l1Lifespan: "5000"
  l1-cleanup-interval: "60000"
```

## ConfigurationBuilder

```
ConfigurationBuilder builder = new ConfigurationBuilder();
builder.clustering().cacheMode(CacheMode.DIST_SYNC)
    .l1()
    .lifespan(5000, TimeUnit.MILLISECONDS)
    .cleanupTaskFrequency(60000, TimeUnit.MILLISECONDS);
```

### 2.2.5. Server hinting

Server hinting increases availability of data in distributed caches by replicating entries across as many servers, racks, and data centers as possible.

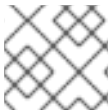

#### NOTE

Server hinting applies only to distributed caches.

When Data Grid distributes the copies of your data, it follows the order of precedence: site, rack, machine, and node. All of the configuration attributes are optional. For example, when you specify only the rack IDs, then Data Grid distributes the copies across different racks and nodes.

Server hinting can impact cluster rebalancing operations by moving more segments than necessary if the number of segments for the cache is too low.

#### TIP

An alternative for clusters in multiple data centers is cross-site replication.

## Server hinting configuration

### XML

```
<cache-container>
  <transport cluster="MyCluster"
    machine="LinuxServer01"
```

```

        rack="Rack01"
        site="US-WestCoast"/>
</cache-container>

```

## JSON

```

{
  "infinispan" : {
    "cache-container" : {
      "transport" : {
        "cluster" : "MyCluster",
        "machine" : "LinuxServer01",
        "rack" : "Rack01",
        "site" : "US-WestCoast"
      }
    }
  }
}

```

## YAML

```

cacheContainer:
  transport:
    cluster: "MyCluster"
    machine: "LinuxServer01"
    rack: "Rack01"
    site: "US-WestCoast"

```

## GlobalConfigurationBuilder

```

GlobalConfigurationBuilder global = GlobalConfigurationBuilder.defaultClusteredBuilder()
    .transport()
    .clusterName("MyCluster")
    .machineId("LinuxServer01")
    .rackId("Rack01")
    .siteId("US-WestCoast");

```

## Additional resources

- [org.infinispan.configuration.global.TransportConfigurationBuilder](https://www.infinispan.org/documentation/8.3/configuration/global/TransportConfigurationBuilder)

### 2.2.6. Key affinity service

In a distributed cache, a key is allocated to a list of nodes with an opaque algorithm. There is no easy way to reverse the computation and generate a key that maps to a particular node. However, Data Grid can generate a sequence of (pseudo-)random keys, see what their primary owner is, and hand them out to the application when it needs a key mapping to a particular node.

Following code snippet depicts how a reference to this service can be obtained and used.

```

// 1. Obtain a reference to a cache
Cache cache = ...

```

```

Address address = cache.getCacheManager().getAddress();

// 2. Create the affinity service
KeyAffinityService keyAffinityService = KeyAffinityServiceFactory.newLocalKeyAffinityService(
    cache,
    new RndKeyGenerator(),
    Executors.newSingleThreadExecutor(),
    100);

// 3. Obtain a key for which the local node is the primary owner
Object localKey = keyAffinityService.getKeyForAddress(address);

// 4. Insert the key in the cache
cache.put(localKey, "yourValue");

```

The service is started at step 2: after this point it uses the supplied *Executor* to generate and queue keys. At step 3, we obtain a key from the service, and at step 4 we use it.

### Lifecycle

**KeyAffinityService** extends **Lifecycle**, which allows stopping and (re)starting it:

```

public interface Lifecycle {
    void start();
    void stop();
}

```

The service is instantiated through **KeyAffinityServiceFactory**. All the factory methods have an **Executor** parameter, that is used for asynchronous key generation (so that it won't happen in the caller's thread). It is the user's responsibility to handle the shutdown of this **Executor**.

The **KeyAffinityService**, once started, needs to be explicitly stopped. This stops the background key generation and releases other held resources.

The only situation in which **KeyAffinityService** stops by itself is when the cache manager with which it was registered is shutdown.

### Topology changes

When the cache topology changes, the ownership of the keys generated by the **KeyAffinityService** might change. The key affinity service keep tracks of these topology changes and doesn't return keys that would currently map to a different node, but it won't do anything about keys generated earlier.

As such, applications should treat **KeyAffinityService** purely as an optimization, and they should not rely on the location of a generated key for correctness.

In particular, applications should not rely on keys generated by **KeyAffinityService** for the same address to always be located together. Collocation of keys is only provided by the **Grouping** API.

## 2.2.7. Grouping API

Complementary to the Key affinity service, the **Grouping** API allows you to co-locate a group of entries on the same nodes, but without being able to select the actual nodes.

By default, the segment of a key is computed using the key's **hashCode()**. If you use the **Grouping** API, Data Grid will compute the segment of the group and use that as the segment of the key.

When the **Grouping** API is in use, it is important that every node can still compute the owners of every

key without contacting other nodes. For this reason, the group cannot be specified manually. The group can either be intrinsic to the entry (generated by the key class) or extrinsic (generated by an external function).

To use the **Grouping** API, you must enable groups.

```
Configuration c = new ConfigurationBuilder()
    .clustering().hash().groups().enabled()
    .build();
```

```
<distributed-cache>
  <groups enabled="true"/>
</distributed-cache>
```

If you have control of the key class (you can alter the class definition, it's not part of an unmodifiable library), then we recommend using an intrinsic group. The intrinsic group is specified by adding the **@Group** annotation to a method, for example:

```
class User {
    ...
    String office;
    ...

    public int hashCode() {
        // Defines the hash for the key, normally used to determine location
        ...
    }

    // Override the location by specifying a group
    // All keys in the same group end up with the same owners
    @Group
    public String getOffice() {
        return office;
    }
}
```

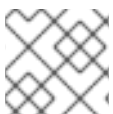

#### NOTE

The group method must return a **String**

If you don't have control over the key class, or the determination of the group is an orthogonal concern to the key class, we recommend using an extrinsic group. An extrinsic group is specified by implementing the **Grouper** interface.

```
public interface Grouper<T> {
    String computeGroup(T key, String group);

    Class<T> getKeyType();
}
```

If multiple **Grouper** classes are configured for the same key type, all of them will be called, receiving the value computed by the previous one. If the key class also has a **@Group** annotation, the first **Grouper**

will receive the group computed by the annotated method. This allows you even greater control over the group when using an intrinsic group.

### Example Grouper implementation

```
public class KXGrouper implements Grouper<String> {

    // The pattern requires a String key, of length 2, where the first character is
    // "k" and the second character is a digit. We take that digit, and perform
    // modular arithmetic on it to assign it to group "0" or group "1".
    private static Pattern kPattern = Pattern.compile("(^k)(<a>\\d</a>$");

    public String computeGroup(String key, String group) {
        Matcher matcher = kPattern.matcher(key);
        if (matcher.matches()) {
            String g = Integer.parseInt(matcher.group(2)) % 2 + "";
            return g;
        } else {
            return null;
        }
    }

    public Class<String> getKeyType() {
        return String.class;
    }
}
```

**Grouper** implementations must be registered explicitly in the cache configuration. If you are configuring Data Grid programmatically:

```
Configuration c = new ConfigurationBuilder()
    .clustering().hash().groups().enabled().addGrouper(new KXGrouper())
    .build();
```

Or, if you are using XML:

```
<distributed-cache>
  <groups enabled="true">
    <grouper class="com.example.KXGrouper" />
  </groups>
</distributed-cache>
```

#### Advanced API

**AdvancedCache** has two group-specific methods:

- **getGroup(groupName)** retrieves all keys in the cache that belong to a group.
- **removeGroup(groupName)** removes all the keys in the cache that belong to a group.

Both methods iterate over the entire data container and store (if present), so they can be slow when a cache contains lots of small groups.

## 2.3. INVALIDATION CACHES

You can use Data Grid in invalidation mode to optimize systems that perform high volumes of read operations. A good example is to use invalidation to prevent lots of database writes when state changes occur.

This cache mode only makes sense if you have another, permanent store for your data such as a database and are only using Data Grid as an optimization in a read-heavy system, to prevent hitting the database for every read. If a cache is configured for invalidation, every time data is changed in a cache, other caches in the cluster receive a message informing them that their data is now stale and should be removed from memory and from any local store.

Figure 2.5. Invalidation cache

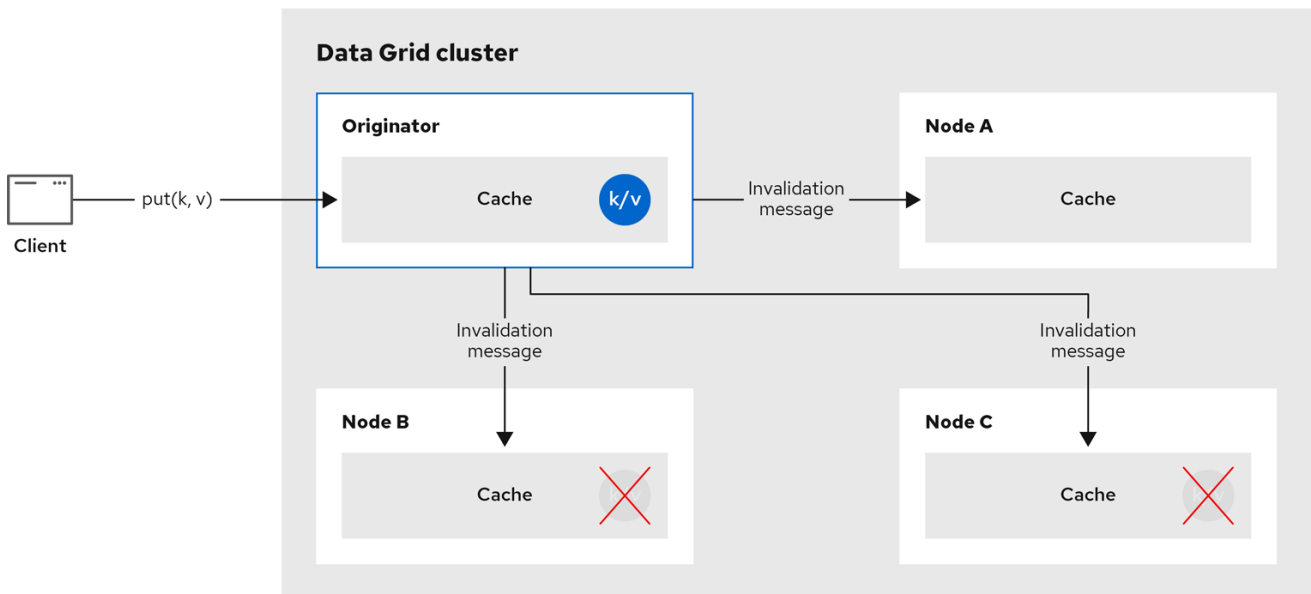

184\_Data\_Grid\_0921

Sometimes the application reads a value from the external store and wants to write it to the local cache, without removing it from the other nodes. To do this, it must call **Cache.putForExternalRead(key, value)** instead of **Cache.put(key, value)**.

Invalidation mode can be used with a shared cache store. A write operation will both update the shared store, and it would remove the stale values from the other nodes' memory. The benefit of this is twofold: network traffic is minimized as invalidation messages are very small compared to replicating the entire value, and also other caches in the cluster look up modified data in a lazy manner, only when needed.



### IMPORTANT

Never use invalidation mode with a local, non-shared, cache store. The invalidation message will not remove entries in the local store, and some nodes will keep seeing the stale value.

An invalidation cache can also be configured with a special cache loader, **ClusterLoader**. When **ClusterLoader** is enabled, read operations that do not find the key on the local node will request it from all the other nodes first, and store it in memory locally. In certain situation it will store stale values, so only use it if you have a high tolerance for stale values.

### Synchronous or asynchronous replication

When synchronous, a write blocks until all nodes in the cluster have evicted the stale value. When asynchronous, the originator broadcasts invalidation messages but does not wait for responses. That means other nodes still see the stale value for a while after the write completed on the originator.

## Transactions

Transactions can be used to batch the invalidation messages. Transactions acquire the key lock on the primary owner.

With pessimistic locking, each write triggers a lock message, which is broadcast to all the nodes. During transaction commit, the originator broadcasts a one-phase prepare message (optionally fire-and-forget) which invalidates all affected keys and releases the locks.

With optimistic locking, the originator broadcasts a prepare message, a commit message, and an unlock message (optional). Either the one-phase prepare or the unlock message is fire-and-forget, and the last message always releases the locks.

## 2.4. SCATTERED CACHES

Scattered caches are very similar to distributed caches as they allow linear scaling of the cluster. Scattered caches allow single node failure by maintaining two copies of the data (**numOwners=2**). Unlike distributed caches, the location of data is not fixed; while we use the same Consistent Hash algorithm to locate the primary owner, the backup copy is stored on the node that wrote the data last time. When the write originates on the primary owner, backup copy is stored on any other node (the exact location of this copy is not important).

This has the advantage of single Remote Procedure Call (RPC) for any write (distributed caches require one or two RPCs), but reads have to always target the primary owner. That results in faster writes but possibly slower reads, and therefore this mode is more suitable for write-intensive applications.

Storing multiple backup copies also results in slightly higher memory consumption. In order to remove out-of-date backup copies, invalidation messages are broadcast in the cluster, which generates some overhead. This lowers the performance of scattered caches in clusters with a large number of nodes.

When a node crashes, the primary copy may be lost. Therefore, the cluster has to reconcile the backups and find out the last written backup copy. This process results in more network traffic during state transfer.

Since the writer of data is also a backup, even if we specify machine/rack/site IDs on the transport level the cluster cannot be resilient to more than one failure on the same machine/rack/site.



### NOTE

You cannot use scattered caches with transactions or asynchronous replication.

The cache is configured in a similar way as the other cache modes, here is an example of declarative configuration:

```
<scattered-cache name="scatteredCache" />
```

```
Configuration c = new ConfigurationBuilder()
    .clustering().cacheMode(CacheMode.SCATTERED_SYNC)
    .build();
```

Scattered mode is not exposed in the server configuration as the server is usually accessed through the

Hot Rod protocol. The protocol automatically selects primary owner for the writes and therefore the write (in distributed mode with two owner) requires single RPC inside the cluster, too. Therefore, scattered cache would not bring the performance benefit.

## 2.5. ASYNCHRONOUS REPLICATION

All clustered cache modes can be configured to use asynchronous communications with the `mode="ASYNC"` attribute on the `<replicated-cache/>`, `<distributed-cache>`, or `<invalidation-cache/>` element.

With asynchronous communications, the originator node does not receive any acknowledgement from the other nodes about the status of the operation, so there is no way to check if it succeeded on other nodes.

We do not recommend asynchronous communications in general, as they can cause inconsistencies in the data, and the results are hard to reason about. Nevertheless, sometimes speed is more important than consistency, and the option is available for those cases.

### Asynchronous API

The Asynchronous API allows you to use synchronous communications, but without blocking the user thread.

There is one caveat: The asynchronous operations do NOT preserve the program order. If a thread calls `cache.putAsync(k, v1)`; `cache.putAsync(k, v2)`, the final value of `k` may be either `v1` or `v2`. The advantage over using asynchronous communications is that the final value can't be `v1` on one node and `v2` on another.

### 2.5.1. Return values with asynchronous replication

Because the `Cache` interface extends `java.util.Map`, write methods like `put(key, value)` and `remove(key)` return the previous value by default.

In some cases, the return value may not be correct:

1. When using `AdvancedCache.withFlags()` with `Flag.IGNORE_RETURN_VALUE`, `Flag.SKIP_REMOTE_LOOKUP`, or `Flag.SKIP_CACHE_LOAD`.
2. When the cache is configured with `unreliable-return-values="true"`.
3. When using asynchronous communications.
4. When there are multiple concurrent writes to the same key, and the cache topology changes. The topology change will make Data Grid retry the write operations, and a retried operation's return value is not reliable.

Transactional caches return the correct previous value in cases 3 and 4. However, transactional caches also have a gotcha: in distributed mode, the read-committed isolation level is implemented as repeatable-read. That means this example of "double-checked locking" won't work:

```
Cache cache = ...
TransactionManager tm = ...

tm.begin();
try {
    Integer v1 = cache.get(k);
    // Increment the value
```



```

Integer v2 = cache.put(k, v1 + 1);
if (Objects.equals(v1, v2) {
    // success
} else {
    // retry
}
} finally {
    tm.commit();
}

```

The correct way to implement this is to use `cache.getAdvancedCache().withFlags(Flag.FORCE_WRITE_LOCK).get(k)`.

In caches with optimistic locking, writes can also return stale previous values. Write skew checks can avoid stale previous values.

## 2.6. CONFIGURING INITIAL CLUSTER SIZE

Data Grid handles cluster topology changes dynamically. This means that nodes do not need to wait for other nodes to join the cluster before Data Grid initializes the caches.

If your applications require a specific number of nodes in the cluster before caches start, you can configure the initial cluster size as part of the transport.

### Procedure

1. Open your Data Grid configuration for editing.
2. Set the minimum number of nodes required before caches start with the **initial-cluster-size** attribute or **initialClusterSize()** method.
3. Set the timeout, in milliseconds, after which the cache manager does not start with the **initial-cluster-timeout** attribute or **initialClusterTimeout()** method.
4. Save and close your Data Grid configuration.

### Initial cluster size configuration

#### XML

```

<infinispan>
  <cache-container>
    <transport initial-cluster-size="4"
      initial-cluster-timeout="30000" />
  </cache-container>
</infinispan>

```

#### JSON

```

{
  "infinispan" : {
    "cache-container" : {
      "transport" : {
        "initial-cluster-size" : "4",

```

```
    "initial-cluster-timeout" : "30000"  
  }  
}  
}
```

## YAML

```
infinispan:  
  cacheContainer:  
    transport:  
      initialClusterSize: "4"  
      initialClusterTimeout: "30000"
```

## ConfigurationBuilder

```
GlobalConfiguration global = GlobalConfigurationBuilder.defaultClusteredBuilder()  
  .transport()  
  .initialClusterSize(4)  
  .initialClusterTimeout(30000, TimeUnit.MILLISECONDS);
```

## CHAPTER 3. DATA GRID CACHE CONFIGURATION

Cache configuration controls how Data Grid stores your data.

As part of your cache configuration, you declare the cache mode you want to use. For instance, you can configure Data Grid clusters to use replicated caches or distributed caches.

Your configuration also defines the characteristics of your caches and enables the Data Grid capabilities that you want to use when handling data. For instance, you can configure how Data Grid encodes entries in your caches, whether replication requests happen synchronously or asynchronously between nodes, if entries are mortal or immortal, and so on.

### 3.1. DECLARATIVE CACHE CONFIGURATION

You can configure caches declaratively, in XML or JSON format, according to the Data Grid schema.

Declarative cache configuration has the following advantages over programmatic configuration:

#### Portability

Define each configuration in a standalone file that you can use to create embedded and remote caches.

You can also use declarative configuration to create caches with Data Grid Operator for clusters running on OpenShift.

#### Simplicity

Keep markup languages separate to programming languages.

For example, to create remote caches it is generally better to not add complex XML directly to Java code.



#### NOTE

Data Grid Server configuration extends **infinispan.xml** to include cluster transport mechanisms, security realms, and endpoint configuration. If you declare caches as part of your Data Grid Server configuration you should use management tooling, such as Ansible or Chef, to keep it synchronized across the cluster.

To dynamically synchronize remote caches across Data Grid clusters, create them at runtime.

#### 3.1.1. Cache configuration

You can create declarative cache configuration in XML, JSON, and YAML format.

All declarative caches must conform to the Data Grid schema. Configuration in JSON format must follow the structure of an XML configuration, elements correspond to objects and attributes correspond to fields.



#### IMPORTANT

Data Grid restricts characters to a maximum of **255** for a cache name or a cache template name. If you exceed this character limit, the Data Grid server might abruptly stop without issuing an exception message. Write succinct cache names and cache template names.



## IMPORTANT

A file system might set a limitation for the length of a file name, so ensure that a cache's name does not exceed this limitation. If a cache name exceeds a file system's naming limitation, general operations or initialing operations towards that cache might fail. Write succinct cache names and cache template names.

## Distributed caches

### XML

```
<distributed-cache owners="2"
  segments="256"
  capacity-factor="1.0"
  l1-lifespan="5000"
  mode="SYNC"
  statistics="true">
  <encoding media-type="application/x-protostream"/>
  <locking isolation="REPEATABLE_READ"/>
  <transaction mode="FULL_XA"
    locking="OPTIMISTIC"/>
  <expiration lifespan="5000"
    max-idle="1000" />
  <memory max-count="1000000"
    when-full="REMOVE"/>
  <indexing enabled="true"
    storage="local-heap">
    <index-reader refresh-interval="1000"/>
  </indexing>
  <partition-handling when-split="ALLOW_READ_WRITES"
    merge-policy="PREFERRED_NON_NULL"/>
  <persistence passivation="false">
    <!-- Persistent storage configuration. -->
  </persistence>
</distributed-cache>
```

### JSON

```
{
  "distributed-cache": {
    "mode": "SYNC",
    "owners": "2",
    "segments": "256",
    "capacity-factor": "1.0",
    "l1-lifespan": "5000",
    "statistics": "true",
    "encoding": {
      "media-type": "application/x-protostream"
    },
    "locking": {
      "isolation": "REPEATABLE_READ"
    },
    "transaction": {
      "mode": "FULL_XA",
```

```

    "locking": "OPTIMISTIC"
  },
  "expiration" : {
    "lifespan" : "5000",
    "max-idle" : "1000"
  },
  "memory": {
    "max-count": "1000000",
    "when-full": "REMOVE"
  },
  "indexing" : {
    "enabled" : true,
    "storage" : "local-heap",
    "index-reader" : {
      "refresh-interval" : "1000"
    }
  },
  "partition-handling" : {
    "when-split" : "ALLOW_READ_WRITES",
    "merge-policy" : "PREFERRED_NON_NULL"
  },
  "persistence" : {
    "passivation" : false
  }
}
}
}

```

## YAML

```

distributedCache:
  mode: "SYNC"
  owners: "2"
  segments: "256"
  capacityFactor: "1.0"
  l1Lifespan: "5000"
  statistics: "true"
  encoding:
    mediaType: "application/x-protostream"
  locking:
    isolation: "REPEATABLE_READ"
  transaction:
    mode: "FULL_XA"
    locking: "OPTIMISTIC"
  expiration:
    lifespan: "5000"
    maxIdle: "1000"
  memory:
    maxCount: "1000000"
    whenFull: "REMOVE"
  indexing:
    enabled: "true"
    storage: "local-heap"
    indexReader:
      refreshInterval: "1000"
  partitionHandling:

```

```

whenSplit: "ALLOW_READ_WRITES"
mergePolicy: "PREFERRED_NON_NULL"
persistence:
  passivation: "false"
  # Persistent storage configuration.

```

## Replicated caches

### XML

```

<replicated-cache segments="256"
  mode="SYNC"
  statistics="true">
  <encoding media-type="application/x-protostream"/>
  <locking isolation="REPEATABLE_READ"/>
  <transaction mode="FULL_XA"
    locking="OPTIMISTIC"/>
  <expiration lifespan="5000"
    max-idle="1000" />
  <memory max-count="1000000"
    when-full="REMOVE"/>
  <indexing enabled="true"
    storage="local-heap">
    <index-reader refresh-interval="1000"/>
  </indexing>
  <partition-handling when-split="ALLOW_READ_WRITES"
    merge-policy="PREFERRED_NON_NULL"/>
  <persistence passivation="false">
    <!-- Persistent storage configuration. -->
  </persistence>
</replicated-cache>

```

### JSON

```

{
  "replicated-cache": {
    "mode": "SYNC",
    "segments": "256",
    "statistics": "true",
    "encoding": {
      "media-type": "application/x-protostream"
    },
    "locking": {
      "isolation": "REPEATABLE_READ"
    },
    "transaction": {
      "mode": "FULL_XA",
      "locking": "OPTIMISTIC"
    },
    "expiration": {
      "lifespan": "5000",
      "max-idle": "1000"
    },
    "memory": {

```

```

    "max-count": "1000000",
    "when-full": "REMOVE"
  },
  "indexing" : {
    "enabled" : true,
    "storage" : "local-heap",
    "index-reader" : {
      "refresh-interval" : "1000"
    }
  },
  "partition-handling" : {
    "when-split" : "ALLOW_READ_WRITES",
    "merge-policy" : "PREFERRED_NON_NULL"
  },
  "persistence" : {
    "passivation" : false
  }
}
}
}

```

## YAML

```

replicatedCache:
  mode: "SYNC"
  segments: "256"
  statistics: "true"
  encoding:
    mediaType: "application/x-protostream"
  locking:
    isolation: "REPEATABLE_READ"
  transaction:
    mode: "FULL_XA"
    locking: "OPTIMISTIC"
  expiration:
    lifespan: "5000"
    maxIdle: "1000"
  memory:
    maxCount: "1000000"
    whenFull: "REMOVE"
  indexing:
    enabled: "true"
    storage: "local-heap"
    indexReader:
      refreshInterval: "1000"
  partitionHandling:
    whenSplit: "ALLOW_READ_WRITES"
    mergePolicy: "PREFERRED_NON_NULL"
  persistence:
    passivation: "false"
  # Persistent storage configuration.

```

## Multiple caches

## XML

```

<infinispan
  xmlns:xsi="http://www.w3.org/2001/XMLSchema-instance"
  xsi:schemaLocation="urn:infinispan:config:13.0 https://infinispan.org/schemas/infinispan-config-
13.0.xsd
                        urn:infinispan:server:13.0 https://infinispan.org/schemas/infinispan-server-13.0.xsd"
  xmlns="urn:infinispan:config:13.0"
  xmlns:server="urn:infinispan:server:13.0">
<cache-container name="default"
  statistics="true">
<distributed-cache name="mycacheone"
  mode="ASYNC"
  statistics="true">
  <encoding media-type="application/x-protostream"/>
  <expiration lifespan="300000"/>
  <memory max-size="400MB"
    when-full="REMOVE"/>
</distributed-cache>
<distributed-cache name="mycachetwo"
  mode="SYNC"
  statistics="true">
  <encoding media-type="application/x-protostream"/>
  <expiration lifespan="300000"/>
  <memory max-size="400MB"
    when-full="REMOVE"/>
</distributed-cache>
</cache-container>
</infinispan>

```

## YAML

```

infinispan:
  cacheContainer:
    name: "default"
    statistics: "true"
  caches:
    mycacheone:
      distributedCache:
        mode: "ASYNC"
        statistics: "true"
        encoding:
          mediaType: "application/x-protostream"
        expiration:
          lifespan: "300000"
        memory:
          maxSize: "400MB"
          whenFull: "REMOVE"
    mycachetwo:
      distributedCache:
        mode: "SYNC"
        statistics: "true"
        encoding:
          mediaType: "application/x-protostream"
        expiration:
          lifespan: "300000"

```



```
memory:
  maxSize: "400MB"
  whenFull: "REMOVE"
```

## JSON

```
{
  "infinispan" : {
    "cache-container" : {
      "name" : "default",
      "statistics" : "true",
      "caches" : {
        "mycacheone" : {
          "distributed-cache" : {
            "mode": "ASYNC",
            "statistics": "true",
            "encoding": {
              "media-type": "application/x-protostream"
            },
            "expiration" : {
              "lifespan" : "300000"
            },
            "memory": {
              "max-size": "400MB",
              "when-full": "REMOVE"
            }
          }
        },
        "mycachetwo" : {
          "distributed-cache" : {
            "mode": "SYNC",
            "statistics": "true",
            "encoding": {
              "media-type": "application/x-protostream"
            },
            "expiration" : {
              "lifespan" : "300000"
            },
            "memory": {
              "max-size": "400MB",
              "when-full": "REMOVE"
            }
          }
        }
      }
    }
  }
}
```

### Additional resources

- [Data Grid configuration schema reference](#)
- [infinispan-config-13.0.xsd](#)

## 3.2. ADDING CACHE TEMPLATES

The Data Grid schema includes **\*-cache-configuration** elements that you can use to create templates. You can then create caches on demand, using the same configuration multiple times.

### Procedure

1. Open your Data Grid configuration for editing.
2. Add the cache configuration with the appropriate **\*-cache-configuration** element or object to the cache manager.
3. Save and close your Data Grid configuration.

### Cache template example

#### XML

```
<infinispan>
  <cache-container>
    <distributed-cache-configuration name="my-dist-template"
      mode="SYNC"
      statistics="true">
      <encoding media-type="application/x-protostream"/>
      <memory max-count="1000000"
        when-full="REMOVE"/>
      <expiration lifespan="5000"
        max-idle="1000"/>
    </distributed-cache-configuration>
  </cache-container>
</infinispan>
```

#### JSON

```
{
  "infinispan" : {
    "cache-container" : {
      "distributed-cache-configuration" : {
        "name" : "my-dist-template",
        "mode": "SYNC",
        "statistics": "true",
        "encoding": {
          "media-type": "application/x-protostream"
        },
        "expiration" : {
          "lifespan" : "5000",
          "max-idle" : "1000"
        },
        "memory": {
          "max-count": "1000000",
          "when-full": "REMOVE"
        }
      }
    }
  }
}
```

```

    }
  }
}

```

## YAML

```

infinispan:
  cacheContainer:
    distributedCacheConfiguration:
      name: "my-dist-template"
      mode: "SYNC"
      statistics: "true"
      encoding:
        mediaType: "application/x-protostream"
      expiration:
        lifespan: "5000"
        maxIdle: "1000"
      memory:
        maxCount: "1000000"
        whenFull: "REMOVE"

```

### 3.2.1. Creating caches from templates

Create caches from configuration templates.

#### TIP

Templates for remote caches are available from the **Cache templates** menu in Data Grid Console.

#### Prerequisites

- Add at least one cache template to the cache manager.

#### Procedure

1. Open your Data Grid configuration for editing.
2. Specify the template from which the cache inherits with the **configuration** attribute or field.
3. Save and close your Data Grid configuration.

#### Cache configuration inherited from a template

#### XML

```

<distributed-cache configuration="my-dist-template" />

```

#### JSON

```

{
  "distributed-cache": {
    "configuration": "my-dist-template"
  }
}

```

```
}
}
```

## YAML

```
distributedCache:
  configuration: "my-dist-template"
```

### 3.2.2. Cache template inheritance

Cache configuration templates can inherit from other templates to extend and override settings.

Cache template inheritance is hierarchical. For a child configuration template to inherit from a parent, you must include it after the parent template.

Additionally, template inheritance is additive for elements that have multiple values. A cache that inherits from another template merges the values from that template, which can override properties.

#### Template inheritance example

## XML

```
<infinispan>
  <cache-container>
    <distributed-cache-configuration name="base-template">
      <expiration lifespan="5000"/>
    </distributed-cache-configuration>
    <distributed-cache-configuration name="extended-template"
      configuration="base-template">
      <encoding media-type="application/x-protostream"/>
      <expiration lifespan="10000"
        max-idle="1000"/>
    </distributed-cache-configuration>
  </cache-container>
</infinispan>
```

## JSON

```
{
  "infinispan" : {
    "cache-container" : {
      "caches" : {
        "base-template" : {
          "distributed-cache-configuration" : {
            "expiration" : {
              "lifespan" : "5000"
            }
          }
        },
        "extended-template" : {
          "distributed-cache-configuration" : {
            "configuration" : "base-template",
            "encoding": {
```

```

    "media-type": "application/x-protostream"
  },
  "expiration" : {
    "lifespan" : "10000",
    "max-idle" : "1000"
  }
}
}
}
}
}
}
}
}
}

```

## YAML

```

infinispan:
  cacheContainer:
  caches:
    base-template:
      distributedCacheConfiguration:
        expiration:
          lifespan: "5000"
    extended-template:
      distributedCacheConfiguration:
        configuration: "base-template"
        encoding:
          mediaType: "application/x-protostream"
        expiration:
          lifespan: "10000"
          maxIdle: "1000"

```

### 3.2.3. Cache template wildcards

You can add wildcards to cache configuration template names. If you then create caches where the name matches the wildcard, Data Grid applies the configuration template.



#### NOTE

Data Grid throws exceptions if cache names match more than one wildcard.

#### Template wildcard example

## XML

```

<infinispan>
  <cache-container>
    <distributed-cache-configuration name="async-dist-cache-*"
      mode="ASYNC"
      statistics="true">
      <encoding media-type="application/x-protostream"/>
    </distributed-cache-configuration>
  </cache-container>
</infinispan>

```

## JSON

```
{
  "infinispan" : {
    "cache-container" : {
      "distributed-cache-configuration" : {
        "name" : "async-dist-cache-*",
        "mode": "ASYNC",
        "statistics": "true",
        "encoding": {
          "media-type": "application/x-protostream"
        }
      }
    }
  }
}
```

## YAML

```
infinispan:
  cacheContainer:
    distributedCacheConfiguration:
      name: "async-dist-cache-*"
      mode: "ASYNC"
      statistics: "true"
      encoding:
        mediaType: "application/x-protostream"
```

Using the preceding example, if you create a cache named "async-dist-cache-prod" then Data Grid uses the configuration from the **async-dist-cache-\*** template.

### 3.2.4. Cache templates from multiple XML files

Split cache configuration templates into multiple XML files for granular flexibility and reference them with XML inclusions (XInclude).

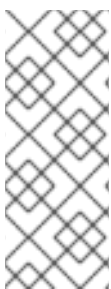

#### NOTE

Data Grid provides minimal support for the XInclude specification. This means you cannot use the **xpointer** attribute, the **xi:fallback** element, text processing, or content negotiation.

You must also add the **xmlns:xi="http://www.w3.org/2001/XInclude"** namespace to **infinispan.xml** to use XInclude.

#### Xinclude cache template

```
<infinispan xmlns:xi="http://www.w3.org/2001/XInclude">
  <cache-container default-cache="cache-1">
    <!-- References files that contain cache configuration templates. -->
    <xi:include href="distributed-cache-template.xml" />
  </cache-container>
</infinispan>
```

```
<xi:include href="replicated-cache-template.xml" />
</cache-container>
</infinispan>
```

Data Grid also provides an **infinispan-config-fragment-13.0.xsd** schema that you can use with configuration fragments.

### Configuration fragment schema

```
<local-cache xmlns:xsi="http://www.w3.org/2001/XMLSchema-instance"
  xsi:schemaLocation="urn:infinispan:config:13.0 https://infinispan.org/schemas/infinispan-
  config-fragment-13.0.xsd"
  xmlns="urn:infinispan:config:13.0"
  name="mycache"/>
```

### Additional resources

- [XInclude specification](#)

## 3.3. CREATING REMOTE CACHES

When you create remote caches at runtime, Data Grid Server synchronizes your configuration across the cluster so that all nodes have a copy. For this reason you should always create remote caches dynamically with the following mechanisms:

- Data Grid Console
- Data Grid Command Line Interface (CLI)
- Hot Rod or HTTP clients

### 3.3.1. Default Cache Manager

Data Grid Server provides a default Cache Manager that controls the lifecycle of remote caches. Starting Data Grid Server automatically instantiates the Cache Manager so you can create and delete remote caches and other resources like Protobuf schema.

After you start Data Grid Server and add user credentials, you can view details about the Cache Manager and get cluster information from Data Grid Console.

- Open **127.0.0.1:11222** in any browser.

You can also get information about the Cache Manager through the Command Line Interface (CLI) or REST API:

#### CLI

Run the **describe** command in the default container.

```
[//containers/default]> describe
```

#### REST

Open **127.0.0.1:11222/rest/v2/cache-managers/default/** in any browser.

## Default Cache Manager configuration

### XML

```
<infinispan>
  <!-- Creates a Cache Manager named "default" and enables metrics. -->
  <cache-container name="default"
    statistics="true">
    <!-- Adds cluster transport that uses the default JGroups TCP stack. -->
    <transport cluster="{infinispan.cluster.name:cluster}"
      stack="{infinispan.cluster.stack:tcp}"
      node-name="{infinispan.node.name:}"/>
    <!-- Requires user permission to access caches and perform operations. -->
    <security>
      <authorization/>
    </security>
  </cache-container>
</infinispan>
```

### JSON

```
{
  "infinispan" : {
    "jgroups" : {
      "transport" : "org.infinispan.remoting.transport.jgroups.JGroupsTransport"
    },
    "cache-container" : {
      "name" : "default",
      "statistics" : "true",
      "transport" : {
        "cluster" : "cluster",
        "node-name" : "",
        "stack" : "tcp"
      },
      "security" : {
        "authorization" : {}
      }
    }
  }
}
```

### YAML

```
infinispan:
  jgroups:
    transport: "org.infinispan.remoting.transport.jgroups.JGroupsTransport"
  cacheContainer:
    name: "default"
    statistics: "true"
  transport:
    cluster: "cluster"
    nodeName: ""
```



```
stack: "tcp"
security:
authorization: ~
```

### 3.3.2. Creating caches with Data Grid Console

Use Data Grid Console to create remote caches in an intuitive visual interface from any web browser.

#### Prerequisites

- Create a Data Grid user with **admin** permissions.
- Start at least one Data Grid Server instance.
- Have a Data Grid cache configuration.

#### Procedure

1. Open **127.0.0.1:11222/console/** in any browser.
2. Select **Create Cache** and follow the steps as Data Grid Console guides you through the process.

### 3.3.3. Creating remote caches with the Data Grid CLI

Use the Data Grid Command Line Interface (CLI) to add remote caches on Data Grid Server.

#### Prerequisites

- Create a Data Grid user with **admin** permissions.
- Start at least one Data Grid Server instance.
- Have a Data Grid cache configuration.

#### Procedure

1. Start the CLI and enter your credentials when prompted.

```
bin/cli.sh
```

2. Use the **create cache** command to create remote caches.  
For example, create a cache named "mycache" from a file named **mycache.xml** as follows:

```
create cache --file=mycache.xml mycache
```

#### Verification

1. List all remote caches with the **ls** command.

```
ls caches
mycache
```

- View cache configuration with the **describe** command.

```
describe caches/mycache
```

### 3.3.4. Creating remote caches from Hot Rod clients

Use the Data Grid Hot Rod API to create remote caches on Data Grid Server from Java, C++, .NET/C#, JS clients and more.

This procedure shows you how to use Hot Rod Java clients that create remote caches on first access. You can find code examples for other Hot Rod clients in the [Data Grid Tutorials](#).

#### Prerequisites

- Create a Data Grid user with **admin** permissions.
- Start at least one Data Grid Server instance.
- Have a Data Grid cache configuration.

#### Procedure

- Invoke the **remoteCache()** method as part of your the **ConfigurationBuilder**.
- Set the **configuration** or **configuration\_uri** properties in the **hotrod-client.properties** file on your classpath.

#### ConfigurationBuilder

```
File file = new File("path/to/infinispan.xml")
ConfigurationBuilder builder = new ConfigurationBuilder();
builder.remoteCache("another-cache")
    .configuration("<distributed-cache name=\"another-cache\"/>");
builder.remoteCache("my.other.cache")
    .configurationURI(file.toURI());
```

#### hotrod-client.properties

```
infinispan.client.hotrod.cache.another-cache.configuration=<distributed-cache name=\"another-cache\"/>
infinispan.client.hotrod.cache.[my.other.cache].configuration_uri=file:///path/to/infinispan.xml
```



#### IMPORTANT

If the name of your remote cache contains the `.` character, you must enclose it in square brackets when using **hotrod-client.properties** files.

#### Additional resources

- [Hot Rod Client Configuration](#)
- [org.infinispan.client.hotrod.configuration.RemoteCacheConfigurationBuilder](#)

### 3.3.5. Creating remote caches with the REST API

Use the Data Grid REST API to create remote caches on Data Grid Server from any suitable HTTP client.

#### Prerequisites

- Create a Data Grid user with **admin** permissions.
- Start at least one Data Grid Server instance.
- Have a Data Grid cache configuration.

#### Procedure

- Invoke **POST** requests to `/rest/v2/caches/<cache_name>` with cache configuration in the payload.

#### Additional resources

- [Creating and Managing Caches with the REST API](#)

## 3.4. CREATING EMBEDDED CACHES

Data Grid provides an **EmbeddedCacheManager** API that lets you control both the Cache Manager and embedded cache lifecycles programmatically.

### 3.4.1. Adding Data Grid to your project

Add Data Grid to your project to create embedded caches in your applications.

#### Prerequisites

- Configure your project to get Data Grid artifacts from the Maven repository.

#### Procedure

- Add the **infinispan-core** artifact as a dependency in your **pom.xml** as follows:

```
<dependencies>
  <dependency>
    <groupId>org.infinispan</groupId>
    <artifactId>infinispan-core</artifactId>
  </dependency>
</dependencies>
```

### 3.4.2. Configuring embedded caches

Data Grid provides a **GlobalConfigurationBuilder** API that controls the cache manager and a **ConfigurationBuilder** API that configures embedded caches.

#### Prerequisites

- Add the **infinispan-core** artifact as a dependency in your **pom.xml**.

### Procedure

1. Initialize the default cache manager so you can add embedded caches.
2. Add at least one embedded cache with the **ConfigurationBuilder** API.
3. Invoke the **getOrCreateCache()** method that either creates embedded caches on all nodes in the cluster or returns caches that already exist.

```
// Set up a clustered cache manager.
GlobalConfigurationBuilder global = GlobalConfigurationBuilder.defaultClusteredBuilder();
// Initialize the default cache manager.
DefaultCacheManager cacheManager = new DefaultCacheManager(global.build());
// Create a distributed cache with synchronous replication.
ConfigurationBuilder builder = new ConfigurationBuilder();
    builder.clustering().cacheMode(CacheMode.DIST_SYNC);
// Obtain a volatile cache.
Cache<String, String> cache =
cacheManager.administration().withFlags(CacheContainerAdmin.AdminFlag.VOLATILE).getOrCreateC
ache("myCache", builder.build());
```

### Additional resources

- [EmbeddedCacheManager](#)
- [EmbeddedCacheManager Configuration](#)
- [org.infinispan.configuration.global.GlobalConfiguration](#)
- [org.infinispan.configuration.cache.ConfigurationBuilder](#)

## CHAPTER 4. ENABLING AND CONFIGURING DATA GRID STATISTICS AND JMX MONITORING

Data Grid can provide Cache Manager and cache statistics as well as export JMX MBeans.

### 4.1. CONFIGURING DATA GRID METRICS

Data Grid generates metrics that are compatible with the MicroProfile Metrics API.

- Gauges provide values such as the average number of nanoseconds for write operations or JVM uptime.
- Histograms provide details about operation execution times such as read, write, and remove times.

By default, Data Grid generates gauges when you enable statistics but you can also configure it to generate histograms.

#### Procedure

1. Open your Data Grid configuration for editing.
2. Add the **metrics** element or object to the cache container.
3. Enable or disable gauges with the **gauges** attribute or field.
4. Enable or disable histograms with the **histograms** attribute or field.
5. Save and close your client configuration.

#### Metrics configuration

##### XML

```
<infinispan>
  <cache-container statistics="true">
    <metrics gauges="true"
      histograms="true" />
  </cache-container>
</infinispan>
```

##### JSON

```
{
  "infinispan" : {
    "cache-container" : {
      "statistics" : "true",
      "metrics" : {
        "gauges" : "true",
        "histograms" : "true"
      }
    }
  }
}
```

```

    }
  }
}

```

## YAML

```

infinispan:
  cacheContainer:
    statistics: "true"
  metrics:
    gauges: "true"
    histograms: "true"

```

## Additional resources

- [Eclipse MicroProfile Metrics](#)

## 4.2. REGISTERING JMX MBEANS

Data Grid can register JMX MBeans that you can use to collect statistics and perform administrative operations. You must also enable statistics otherwise Data Grid provides **0** values for all statistic attributes in JMX MBeans.

### Procedure

1. Open your Data Grid configuration for editing.
2. Add the **jmx** element or object to the cache container and specify **true** as the value for the **enabled** attribute or field.
3. Add the **domain** attribute or field and specify the domain where JMX MBeans are exposed, if required.
4. Save and close your client configuration.

## JMX configuration

### XML

```

<infinispan>
  <cache-container statistics="true">
    <jmx enabled="true"
      domain="example.com"/>
  </cache-container>
</infinispan>

```

### JSON

```

{
  "infinispan" : {
    "cache-container" : {
      "statistics" : "true",

```

```

"jmx" : {
  "enabled" : "true",
  "domain" : "example.com"
}
}
}
}

```

## YAML

```

infinispan:
  cacheContainer:
    statistics: "true"
  jmx:
    enabled: "true"
    domain: "example.com"

```

### 4.2.1. Enabling JMX remote ports

Provide unique remote JMX ports to expose Data Grid MBeans through connections in JMXServiceURL format.

You can enable remote JMX ports using one of the following approaches:

- Enable remote JMX ports that require authentication to one of the Data Grid Server security realms.
- Enable remote JMX ports manually using the standard Java management configuration options.

#### Prerequisites

- For remote JMX with authentication, define user roles using the default security realm. Users must have **controlRole** with read/write access or the **monitorRole** with read-only access to access any JMX resources.

#### Procedure

Start Data Grid Server with a remote JMX port enabled using one of the following ways:

- Enable remote JMX through port **9999**.

```
bin/server.sh --jmx 9999
```



#### WARNING

Using remote JMX with SSL disabled is not intended for production environments.

- Pass the following system properties to Data Grid Server at startup.

```
bin/server.sh -Dcom.sun.management.jmxremote.port=9999 -  
Dcom.sun.management.jmxremote.authenticate=false -  
Dcom.sun.management.jmxremote.ssl=false
```



#### WARNING

Enabling remote JMX with no authentication or SSL is not secure and not recommended in any environment. Disabling authentication and SSL allows unauthorized users to connect to your server and access the data hosted there.

#### Additional resources

- [Creating security realms](#)

### 4.2.2. Data Grid MBeans

Data Grid exposes JMX MBeans that represent manageable resources.

#### **org.infinispan:type=Cache**

Attributes and operations available for cache instances.

#### **org.infinispan:type=CacheManager**

Attributes and operations available for cache managers, including Data Grid cache and cluster health statistics.

For a complete list of available JMX MBeans along with descriptions and available operations and attributes, see the *Data Grid JMX Components* documentation.

#### Additional resources

- [Data Grid JMX Components](#)

### 4.2.3. Registering MBeans in custom MBean servers

Data Grid includes an **MBeanServerLookup** interface that you can use to register MBeans in custom MBeanServer instances.

#### Prerequisites

- Create an implementation of **MBeanServerLookup** so that the **getMBeanServer()** method returns the custom MBeanServer instance.
- Configure Data Grid to register JMX MBeans.

#### Procedure



1. Open your Data Grid configuration for editing.
2. Add the **mbean-server-lookup** attribute or field to the JMX configuration for the cache manager.
3. Specify fully qualified name (FQN) of your **MBeanServerLookup** implementation.
4. Save and close your client configuration.

### JMX MBean server lookup configuration

#### XML

```
<infinispan>
  <cache-container statistics="true">
    <jmx enabled="true"
      domain="example.com"
      mbean-server-lookup="com.example.MyMBeanServerLookup"/>
  </cache-container>
</infinispan>
```

#### JSON

```
{
  "infinispan" : {
    "cache-container" : {
      "statistics" : "true",
      "jmx" : {
        "enabled" : "true",
        "domain" : "example.com",
        "mbean-server-lookup" : "com.example.MyMBeanServerLookup"
      }
    }
  }
}
```

#### YAML

```
infinispan:
  cacheContainer:
    statistics: "true"
  jmx:
    enabled: "true"
    domain: "example.com"
    mbeanServerLookup: "com.example.MyMBeanServerLookup"
```

## CHAPTER 5. CONFIGURING JVM MEMORY USAGE

Control how Data Grid stores data in JVM memory by:

- Managing JVM memory usage with eviction that automatically removes data from caches.
- Adding lifespan and maximum idle times to expire entries and prevent stale data.
- Configuring Data Grid to store data in off-heap, native memory.

### 5.1. DEFAULT MEMORY CONFIGURATION

By default Data Grid stores cache entries as objects in the JVM heap. Over time, as applications add entries, the size of caches can exceed the amount of memory that is available to the JVM. Likewise, if Data Grid is not the primary data store, then entries become out of date which means your caches contain stale data.

#### XML

```
<distributed-cache>
  <memory storage="HEAP"/>
</distributed-cache>
```

#### JSON

```
{
  "distributed-cache": {
    "memory": {
      "storage": "HEAP"
    }
  }
}
```

#### YAML

```
distributedCache:
  memory:
    storage: "HEAP"
```

### 5.2. EVICTION AND EXPIRATION

Eviction and expiration are two strategies for cleaning the data container by removing old, unused entries. Although eviction and expiration are similar, they have some important differences.

- ✓ Eviction lets Data Grid control the size of the data container by removing entries when the container becomes larger than a configured threshold.
- ✓ Expiration limits the amount of time entries can exist. Data Grid uses a scheduler to periodically remove expired entries. Entries that are expired but not yet removed are immediately removed on access; in this case **get()** calls for expired entries return "null" values.
- ✓ Eviction is local to Data Grid nodes.

- ✓ Expiration takes place across Data Grid clusters.
- ✓ You can use eviction and expiration together or independently of each other.
- ✓ You can configure eviction and expiration declaratively in **infinispan.xml** to apply cache-wide defaults for entries.
- ✓ You can explicitly define expiration settings for specific entries but you cannot define eviction on a per-entry basis.
- ✓ You can manually evict entries and manually trigger expiration.

## 5.3. EVICTION WITH DATA GRID CACHES

Eviction lets you control the size of the data container by removing entries from memory in one of two ways:

- Total number of entries (**max-count**).
- Maximum amount of memory (**max-size**).

Eviction drops one entry from the data container at a time and is local to the node on which it occurs.



### IMPORTANT

Eviction removes entries from memory but not from persistent cache stores. To ensure that entries remain available after Data Grid evicts them, and to prevent inconsistencies with your data, you should configure persistent storage.

When you configure **memory**, Data Grid approximates the current memory usage of the data container. When entries are added or modified, Data Grid compares the current memory usage of the data container to the maximum size. If the size exceeds the maximum, Data Grid performs eviction.

Eviction happens immediately in the thread that adds an entry that exceeds the maximum size.

### 5.3.1. Eviction strategies

When you configure Data Grid eviction you specify:

- The maximum size of the data container.
- A strategy for removing entries when the cache reaches the threshold.

You can either perform eviction manually or configure Data Grid to do one of the following:

- Remove old entries to make space for new ones.
- Throw **ContainerFullException** and prevent new entries from being created. The exception eviction strategy works only with transactional caches that use 2 phase commits; not with 1 phase commits or synchronization optimizations.

Refer to the schema reference for more details about the eviction strategies.

**NOTE**

Data Grid includes the Caffeine caching library that implements a variation of the Least Frequently Used (LFU) cache replacement algorithm known as TinyLFU. For off-heap storage, Data Grid uses a custom implementation of the Least Recently Used (LRU) algorithm.

**Additional resources**

- [Caffeine](#)
- [Data Grid configuration schema reference](#)

**5.3.2. Configuring maximum count eviction**

Limit the size of Data Grid caches to a total number of entries.

**Procedure**

1. Open your Data Grid configuration for editing.
2. Specify the total number of entries that caches can contain before Data Grid performs eviction with either the **max-count** attribute or **maxCount()** method.
3. Set one of the following as the eviction strategy to control how Data Grid removes entries with the **when-full** attribute or **whenFull()** method.
  - **REMOVE** Data Grid performs eviction. This is the default strategy.
  - **MANUAL** You perform eviction manually for embedded caches.
  - **EXCEPTION** Data Grid throws an exception instead of evicting entries.
4. Save and close your Data Grid configuration.

**Maximum count eviction**

In the following example, Data Grid removes an entry when the cache contains a total of 500 entries and a new entry is created:

**XML**

```
<distributed-cache>
  <memory max-count="500" when-full="REMOVE"/>
</distributed-cache>
```

**JSON**

```
{
  "distributed-cache" : {
    "memory" : {
      "max-count" : "500",
      "when-full" : "REMOVE"
    }
  }
}
```

```

    }
  }
}

```

## YAML

```

distributedCache:
  memory:
    maxCount: "500"
    whenFull: "REMOVE"

```

## ConfigurationBuilder

```

ConfigurationBuilder builder = new ConfigurationBuilder();
builder.memory().maxCount(500).whenFull(EvictionStrategy.REMOVE);

```

## Additional resources

- [Data Grid configuration schema reference](#)
- [org.infinispan.configuration.cache.MemoryConfigurationBuilder](#)

### 5.3.3. Configuring maximum size eviction

Limit the size of Data Grid caches to a maximum amount of memory.

#### Procedure

1. Open your Data Grid configuration for editing.
2. Specify **application/x-protostream** as the media type for cache encoding.  
You must specify a binary media type to use maximum size eviction.
3. Configure the maximum amount of memory, in bytes, that caches can use before Data Grid performs eviction with the **max-size** attribute or **maxSize()** method.
4. Optionally specify a byte unit of measurement.  
The default is B (bytes). Refer to the configuration schema for supported units.
5. Set one of the following as the eviction strategy to control how Data Grid removes entries with either the **when-full** attribute or **whenFull()** method.
  - **REMOVE** Data Grid performs eviction. This is the default strategy.
  - **MANUAL** You perform eviction manually for embedded caches.
  - **EXCEPTION** Data Grid throws an exception instead of evicting entries.
6. Save and close your Data Grid configuration.

#### Maximum size eviction

In the following example, Data Grid removes an entry when the size of the cache reaches 1.5 GB (gigabytes) and a new entry is created:

## XML

```
<distributed-cache>
  <encoding media-type="application/x-protostream"/>
  <memory max-size="1.5GB" when-full="REMOVE"/>
</distributed-cache>
```

## JSON

```
{
  "distributed-cache" : {
    "encoding" : {
      "media-type" : "application/x-protostream"
    },
    "memory" : {
      "max-size" : "1.5GB",
      "when-full" : "REMOVE"
    }
  }
}
```

## YAML

```
distributedCache:
  encoding:
    mediaType: "application/x-protostream"
  memory:
    maxSize: "1.5GB"
    whenFull: "REMOVE"
```

## ConfigurationBuilder

```
ConfigurationBuilder builder = new ConfigurationBuilder();
builder.encoding().mediaType("application/x-protostream")
  .memory()
  .maxSize("1.5GB")
  .whenFull(EvictionStrategy.REMOVE);
```

## Additional resources

- [Data Grid configuration schema reference](#)
- [org.infinispan.configuration.cache.EncodingConfiguration](#)
- [org.infinispan.configuration.cache.MemoryConfigurationBuilder](#)
- [Cache Encoding and Marshalling](#)

### 5.3.4. Manual eviction

If you choose the manual eviction strategy, Data Grid does not perform eviction. You must do so manually with the **evict()** method.

You should use manual eviction with embedded caches only. For remote caches, you should always configure Data Grid with the **REMOVE** or **EXCEPTION** eviction strategy.



## NOTE

This configuration prevents a warning message when you enable passivation but do not configure eviction.

### XML

```
<distributed-cache>
  <memory max-count="500" when-full="MANUAL"/>
</distributed-cache>
```

### JSON

```
{
  "distributed-cache" : {
    "memory" : {
      "max-count" : "500",
      "when-full" : "MANUAL"
    }
  }
}
```

### YAML

```
distributedCache:
  memory:
    maxCount: "500"
    whenFull: "MANUAL"
```

### ConfigurationBuilder

```
ConfigurationBuilder builder = new ConfigurationBuilder();
builder.encoding().mediaType("application/x-protostream")
  .memory()
  .maxSize("1.5GB")
  .whenFull(EvictionStrategy.REMOVE);
```

## 5.3.5. Passivation with eviction

Passivation persists data to cache stores when Data Grid evicts entries. You should always enable eviction if you enable passivation, as in the following examples:

### XML

```
<distributed-cache>
  <persistence passivation="true">
    <!-- Persistent storage configuration. -->
```

```

</persistence>
<memory max-count="100"/>
</distributed-cache>

```

## JSON

```

{
  "distributed-cache": {
    "memory": {
      "max-count": "100"
    },
    "persistence": {
      "passivation": true
    }
  }
}

```

## YAML

```

distributedCache:
  memory:
    maxCount: "100"
  persistence:
    passivation: "true"

```

## ConfigurationBuilder

```

ConfigurationBuilder builder = new ConfigurationBuilder();
builder.memory().maxCount(100);
builder.persistence().passivation(true); //Persistent storage configuration

```

## 5.4. EXPIRATION WITH LIFESPAN AND MAXIMUM IDLE

Expiration configures Data Grid to remove entries from caches when they reach one of the following time limits:

### Lifespan

Sets the maximum amount of time that entries can exist.

### Maximum idle

Specifies how long entries can remain idle. If operations do not occur for entries, they become idle.



### IMPORTANT

Maximum idle expiration does not currently support caches with persistent storage.



### NOTE

If you use expiration and eviction with the **EXCEPTION** eviction strategy, entries that are expired, but not yet removed from the cache, count towards the size of the data container.



### 5.4.1. How expiration works

When you configure expiration, Data Grid stores keys with metadata that determines when entries expire.

- Lifespan uses a **creation** timestamp and the value for the **lifespan** configuration property.
- Maximum idle uses a **last used** timestamp and the value for the **max-idle** configuration property.

Data Grid checks if lifespan or maximum idle metadata is set and then compares the values with the current time.

If **(creation + lifespan < currentTime)** or **(lastUsed + maxIdle < currentTime)** then Data Grid detects that the entry is expired.

Expiration occurs whenever entries are accessed or found by the expiration reaper.

For example, **k1** reaches the maximum idle time and a client makes a **Cache.get(k1)** request. In this case, Data Grid detects that the entry is expired and removes it from the data container. The **Cache.get(k1)** request returns **null**.

Data Grid also expires entries from cache stores, but only with lifespan expiration. Maximum idle expiration does not work with cache stores. In the case of cache loaders, Data Grid cannot expire entries because loaders can only read from external storage.

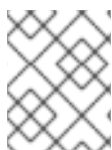

#### NOTE

Data Grid adds expiration metadata as **long** primitive data types to cache entries. This can increase the size of keys by as much as 32 bytes.

### 5.4.2. Expiration reaper

Data Grid uses a reaper thread that runs periodically to detect and remove expired entries. The expiration reaper ensures that expired entries that are no longer accessed are removed.

The Data Grid **ExpirationManager** interface handles the expiration reaper and exposes the **processExpiration()** method.

In some cases, you can disable the expiration reaper and manually expire entries by calling **processExpiration()**; for instance, if you are using local cache mode with a custom application where a maintenance thread runs periodically.



#### IMPORTANT

If you use clustered cache modes, you should never disable the expiration reaper.

Data Grid always uses the expiration reaper when using cache stores. In this case you cannot disable it.

#### Additional resources

- [org.infinispan.configuration.cache.ExpirationConfigurationBuilder](http://org.infinispan.configuration.cache.ExpirationConfigurationBuilder)
- [org.infinispan.expiration.ExpirationManager](http://org.infinispan.expiration.ExpirationManager)

### 5.4.3. Maximum idle and clustered caches

Because maximum idle expiration relies on the last access time for cache entries, it has some limitations with clustered cache modes.

With lifespan expiration, the creation time for cache entries provides a value that is consistent across clustered caches. For example, the creation time for **k1** is always the same on all nodes.

For maximum idle expiration with clustered caches, last access time for entries is not always the same on all nodes. To ensure that entries have the same relative access times across clusters, Data Grid sends touch commands to all owners when keys are accessed.

The touch commands that Data Grid send have the following considerations:

- **Cache.get()** requests do not return until all touch commands complete. This synchronous behavior increases latency of client requests.
- The touch command also updates the "recently accessed" metadata for cache entries on all owners, which Data Grid uses for eviction.
- With scattered cache mode, Data Grid sends touch commands to all nodes, not just primary and backup owners.

#### Additional information

- Maximum idle expiration does not work with invalidation mode.
- Iteration across a clustered cache can return expired entries that have exceeded the maximum idle time limit. This behavior ensures performance because no remote invocations are performed during the iteration. Also note that iteration does not refresh any expired entries.

### 5.4.4. Configuring lifespan and maximum idle times for caches

Set lifespan and maximum idle times for all entries in a cache.

#### Procedure

1. Open your Data Grid configuration for editing.
2. Specify the amount of time, in milliseconds, that entries can stay in the cache with the **lifespan** attribute or **lifespan()** method.
3. Specify the amount of time, in milliseconds, that entries can remain idle after last access with the **max-idle** attribute or **maxIdle()** method.
4. Save and close your Data Grid configuration.

#### Expiration for Data Grid caches

In the following example, Data Grid expires all cache entries after 5 seconds or 1 second after the last access time, whichever happens first:

#### XML

```
<replicated-cache>
  <expiration lifespan="5000" max-idle="1000" />
</replicated-cache>
```

## JSON

```
{
  "replicated-cache" : {
    "expiration" : {
      "lifespan" : "5000",
      "max-idle" : "1000"
    }
  }
}
```

## YAML

```
replicatedCache:
  expiration:
    lifespan: "5000"
    maxIdle: "1000"
```

## ConfigurationBuilder

```
ConfigurationBuilder builder = new ConfigurationBuilder();
builder.expiration().lifespan(5000, TimeUnit.MILLISECONDS)
    .maxIdle(1000, TimeUnit.MILLISECONDS);
```

### 5.4.5. Configuring lifespan and maximum idle times per entry

Specify lifespan and maximum idle times for individual entries. When you add lifespan and maximum idle times to entries, those values take priority over expiration configuration for caches.



#### NOTE

When you explicitly define lifespan and maximum idle time values for cache entries, Data Grid replicates those values across the cluster along with the cache entries. Likewise, Data Grid writes expiration values along with the entries to persistent storage.

#### Procedure

- For remote caches, you can add lifespan and maximum idle times to entries interactively with the Data Grid Console. With the Data Grid Command Line Interface (CLI), use the **--max-idle=** and **--ttl=** arguments with the **put** command.
- For both remote and embedded caches, you can add lifespan and maximum idle times with **cache.put()** invocations.

```
//Lifespan of 5 seconds.
//Maximum idle time of 1 second.
```

```

cache.put("hello", "world", 5, TimeUnit.SECONDS, 1, TimeUnit.SECONDS);

//Lifespan is disabled with a value of -1.
//Maximum idle time of 1 second.
cache.put("hello", "world", -1, TimeUnit.SECONDS, 1, TimeUnit.SECONDS);

```

### Additional resources

- [org.infinispan.configuration.cache.ExpirationConfigurationBuilder](https://www.infinispan.org/documentation/11.0/en/configuration/cache/ExpirationConfigurationBuilder)
- [org.infinispan.expiration.ExpirationManager](https://www.infinispan.org/documentation/11.0/en/expiration/ExpirationManager)

## 5.5. JVM HEAP AND OFF-HEAP MEMORY

Data Grid stores cache entries in JVM heap memory by default. You can configure Data Grid to use off-heap storage, which means that your data occupies native memory outside the managed JVM memory space.

The following diagram is a simplified illustration of the memory space for a JVM process where Data Grid is running:

Figure 5.1. JVM memory space

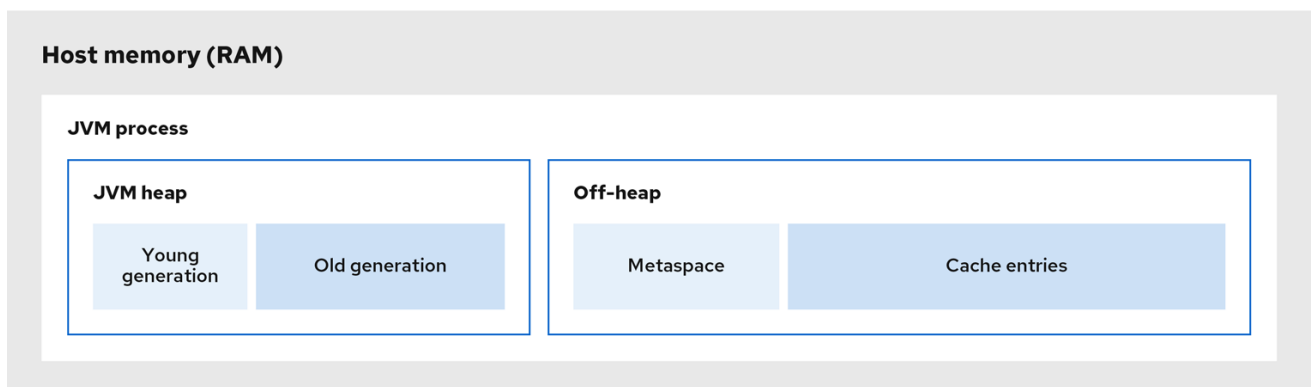

184\_Data\_Grid\_0921

### JVM heap memory

The heap is divided into young and old generations that help keep referenced Java objects and other application data in memory. The GC process reclaims space from unreachable objects, running more frequently on the young generation memory pool.

When Data Grid stores cache entries in JVM heap memory, GC runs can take longer to complete as you start adding data to your caches. Because GC is an intensive process, longer and more frequent runs can degrade application performance.

### Off-heap memory

Off-heap memory is native available system memory outside JVM memory management. The *JVM memory space* diagram shows the **Metaspace** memory pool that holds class metadata and is allocated from native memory. The diagram also represents a section of native memory that holds Data Grid cache entries.

Off-heap memory:

- Uses less memory per entry.

- Improves overall JVM performance by avoiding Garbage Collector (GC) runs.

One disadvantage, however, is that JVM heap dumps do not show entries stored in off-heap memory.

### 5.5.1. Off-heap data storage

When you add entries to off-heap caches, Data Grid dynamically allocates native memory to your data.

Data Grid hashes the serialized `byte[]` for each key into buckets that are similar to a standard Java **HashMap**. Buckets include address pointers that Data Grid uses to locate entries that you store in off-heap memory.



#### IMPORTANT

Even though Data Grid stores cache entries in native memory, run-time operations require JVM heap representations of those objects. For instance, **cache.get()** operations read objects into heap memory before returning. Likewise, state transfer operations hold subsets of objects in heap memory while they take place.

#### Object equality

Data Grid determines equality of Java objects in off-heap storage using the serialized `byte[]` representation of each object instead of the object instance.

#### Data consistency

Data Grid uses an array of locks to protect off-heap address spaces. The number of locks is twice the number of cores and then rounded to the nearest power of two. This ensures that there is an even distribution of **ReadWriteLock** instances to prevent write operations from blocking read operations.

### 5.5.2. Configuring off-heap memory

Configure Data Grid to store cache entries in native memory outside the JVM heap space.

#### Procedure

1. Open your Data Grid configuration for editing.
2. Set **OFF\_HEAP** as the value for the **storage** attribute or **storage()** method.
3. Set a boundary for the size of the cache by configuring eviction.
4. Save and close your Data Grid configuration.

#### Off-heap storage

Data Grid stores cache entries as bytes in native memory. Eviction happens when there are 100 entries in the data container and Data Grid gets a request to create a new entry:

#### XML

```
<replicated-cache>
  <memory storage="OFF_HEAP" max-count="500"/>
</replicated-cache>
```

## JSON

```
{
  "replicated-cache" : {
    "memory" : {
      "storage" : "OBJECT",
      "max-count" : "500"
    }
  }
}
```

## YAML

```
replicatedCache:
  memory:
    storage: "OFF_HEAP"
    maxCount: "500"
```

## ConfigurationBuilder

```
ConfigurationBuilder builder = new ConfigurationBuilder();
builder.memory().storage(StorageType.OFF_HEAP).maxCount(500);
```

## Additional resources

- [Data Grid configuration schema reference](#)
- [org.infinispan.configuration.cache.MemoryConfigurationBuilder](#)

## CHAPTER 6. CONFIGURING PERSISTENT STORAGE

Data Grid uses cache stores and loaders to interact with persistent storage.

### Durability

Adding cache stores allows you to persist data to non-volatile storage so it survives restarts.

### Write-through caching

Configuring Data Grid as a caching layer in front of persistent storage simplifies data access for applications because Data Grid handles all interactions with the external storage.

### Data overflow

Using eviction and passivation techniques ensures that Data Grid keeps only frequently used data in-memory and writes older entries to persistent storage.

## 6.1. PASSIVATION

Passivation configures Data Grid to write entries to cache stores when it evicts those entries from memory. In this way, passivation ensures that only a single copy of an entry is maintained, either in-memory or in a cache store, which prevents unnecessary and potentially expensive writes to persistent storage.

Activation is the process of restoring entries to memory from the cache store when there is an attempt to access passivated entries. For this reason, when you enable passivation, you must configure cache stores that implement both **CacheWriter** and **CacheLoader** interfaces so they can write and load entries from persistent storage.

When Data Grid evicts an entry from the cache, it notifies cache listeners that the entry is passivated then stores the entry in the cache store. When Data Grid gets an access request for an evicted entry, it lazily loads the entry from the cache store into memory and then notifies cache listeners that the entry is activated.



### NOTE

- Passivation uses the first cache loader in the Data Grid configuration and ignores all others.
- Passivation is not supported with:
  - Transactional stores. Passivation writes and removes entries from the store outside the scope of the actual Data Grid commit boundaries.
  - Shared stores. Shared cache stores require entries to always exist in the store for other owners. For this reason, passivation is not supported because entries cannot be removed.

If you enable passivation with transactional stores or shared stores, Data Grid throws an exception.

### 6.1.1. How passivation works

#### Passivation disabled

Writes to data in memory result in writes to persistent storage.

If Data Grid evicts data from memory, then data in persistent storage includes entries that are evicted from memory. In this way persistent storage is a superset of the in-memory cache.

If you do not configure eviction, then data in persistent storage provides a copy of data in memory.

### Passivation enabled

Data Grid adds data to persistent storage only when it evicts data from memory.

When Data Grid activates entries, it restores data in memory and deletes data from persistent storage. In this way, data in memory and data in persistent storage form separate subsets of the entire data set, with no intersection between the two.



#### NOTE

Entries in persistent storage can become stale when using shared cache stores. This occurs because Data Grid does not delete passivated entries from shared cache stores when they are activated.

Values are updated in memory but previously passivated entries remain in persistent storage with out of date values.

The following table shows data in memory and in persistent storage after a series of operations:

Operation	Passivation disabled	Passivation enabled	Passivation enabled with shared cache store
Insert k1.	<b>Memory:</b> k1 <b>Disk:</b> k1	<b>Memory:</b> k1 <b>Disk:</b> -	<b>Memory:</b> k1 <b>Disk:</b> -
Insert k2.	<b>Memory:</b> k1, k2 <b>Disk:</b> k1, k2	<b>Memory:</b> k1, k2 <b>Disk:</b> -	<b>Memory:</b> k1, k2 <b>Disk:</b> -
Eviction thread runs and evicts k1.	<b>Memory:</b> k2 <b>Disk:</b> k1, k2	<b>Memory:</b> k2 <b>Disk:</b> k1	<b>Memory:</b> k2 <b>Disk:</b> k1
Read k1.	<b>Memory:</b> k1, k2 <b>Disk:</b> k1, k2	<b>Memory:</b> k1, k2 <b>Disk:</b> -	<b>Memory:</b> k1, k2 <b>Disk:</b> k1
Eviction thread runs and evicts k2.	<b>Memory:</b> k1 <b>Disk:</b> k1, k2	<b>Memory:</b> k1 <b>Disk:</b> k2	<b>Memory:</b> k1 <b>Disk:</b> k1, k2
Remove k2.	<b>Memory:</b> k1 <b>Disk:</b> k1	<b>Memory:</b> k1 <b>Disk:</b> -	<b>Memory:</b> k1 <b>Disk:</b> k1

## 6.2. WRITE-THROUGH CACHE STORES

Write-through is a cache writing mode where writes to memory and writes to cache stores are synchronous. When a client application updates a cache entry, in most cases by invoking **Cache.put()**, Data Grid does not return the call until it updates the cache store. This cache writing mode results in updates to the cache store concluding within the boundaries of the client thread.



The primary advantage of write-through mode is that the cache and cache store are updated simultaneously, which ensures that the cache store is always consistent with the cache.

However, write-through mode can potentially decrease performance because the need to access and update cache stores directly adds latency to cache operations.

### Write-through configuration

Data Grid uses write-through mode unless you explicitly add write-behind configuration to your caches. There is no separate element or method for configuring write-through mode.

For example, the following configuration adds a file-based store to the cache that implicitly uses write-through mode:

```
<distributed-cache>
  <persistence passivation="false">
    <file-store fetch-state="true">
      <index path="path/to/index" />
      <data path="path/to/data" />
    </file-store>
  </persistence>
</distributed-cache>
```

## 6.3. WRITE-BEHIND CACHE STORES

Write-behind is a cache writing mode where writes to memory are synchronous and writes to cache stores are asynchronous.

When clients send write requests, Data Grid adds those operations to a modification queue. Data Grid processes operations as they join the queue so that the calling thread is not blocked and the operation completes immediately.

If the number of write operations in the modification queue increases beyond the size of the queue, Data Grid adds those additional operations to the queue. However, those operations do not complete until Data Grid processes operations that are already in the queue.

For example, calling **Cache.putAsync** returns immediately and the Stage also completes immediately if the modification queue is not full. If the modification queue is full, or if Data Grid is currently processing a batch of write operations, then **Cache.putAsync** returns immediately and the Stage completes later.

Write-behind mode provides a performance advantage over write-through mode because cache operations do not need to wait for updates to the underlying cache store to complete. However, data in the cache store remains inconsistent with data in the cache until the modification queue is processed. For this reason, write-behind mode is suitable for cache stores with low latency, such as unshared and local file-based cache stores, where the time between the write to the cache and the write to the cache store is as small as possible.

### Write-behind configuration

#### XML

```
<distributed-cache>
  <persistence>
    <table-jdbc-store xmlns="urn:infinispan:config:store:sql:13.0"
      dialect="H2"
      shared="true"
```

```

        table-name="books">
<connection-pool connection-url="jdbc:h2:mem:infinispan"
    username="sa"
    password="changeme"
    driver="org.h2.Driver"/>
<write-behind modification-queue-size="2048"
    fail-silently="true"/>
</table-jdbc-store>
</persistence>
</distributed-cache>

```

## JSON

```

{
  "distributed-cache": {
    "persistence" : {
      "table-jdbc-store": {
        "dialect": "H2",
        "shared": "true",
        "table-name": "books",
        "connection-pool": {
          "connection-url": "jdbc:h2:mem:infinispan",
          "driver": "org.h2.Driver",
          "username": "sa",
          "password": "changeme"
        },
        "write-behind" : {
          "modification-queue-size" : "2048",
          "fail-silently" : true
        }
      }
    }
  }
}

```

## YAML

```

distributedCache:
  persistence:
    tableJdbcStore:
      dialect: "H2"
      shared: "true"
      tableName: "books"
      connectionPool:
        connectionUrl: "jdbc:h2:mem:infinispan"
        driver: "org.h2.Driver"
        username: "sa"
        password: "changeme"
      writeBehind:
        modificationQueueSize: "2048"
        failSilently: "true"

```

## ConfigurationBuilder

```

ConfigurationBuilder builder = new ConfigurationBuilder();
builder.persistence()
    .async()
    .modificationQueueSize(2048)
    .failSilently(true);

```

### Failing silently

Write-behind configuration includes a **fail-silently** parameter that controls what happens when either the cache store is unavailable or the modification queue is full.

- If **fail-silently="true"** then Data Grid logs WARN messages and rejects write operations.
- If **fail-silently="false"** then Data Grid throws exceptions if it detects the cache store is unavailable during a write operation. Likewise if the modification queue becomes full, Data Grid throws an exception.

In some cases, data loss can occur if Data Grid restarts and write operations exist in the modification queue. For example the cache store goes offline but, during the time it takes to detect that the cache store is unavailable, write operations are added to the modification queue because it is not full. If Data Grid restarts or otherwise becomes unavailable before the cache store comes back online, then the write operations in the modification queue are lost because they were not persisted.

## 6.4. SEGMENTED CACHE STORES

Cache stores can organize data into hash space segments to which keys map.

Segmented stores increase read performance for bulk operations; for example, streaming over data (**Cache.size**, **Cache.entrySet.stream**), pre-loading the cache, and doing state transfer operations.

However, segmented stores can also result in loss of performance for write operations. This performance loss applies particularly to batch write operations that can take place with transactions or write-behind stores. For this reason, you should evaluate the overhead for write operations before you enable segmented stores. The performance gain for bulk read operations might not be acceptable if there is a significant performance loss for write operations.

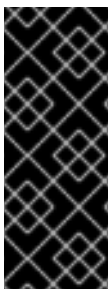

### IMPORTANT

The number of segments you configure for cache stores must match the number of segments you define in the Data Grid configuration with the **clustering.hash.numSegments** parameter.

If you change the **numSegments** parameter in the configuration after you add a segmented cache store, Data Grid cannot read data from that cache store.

## 6.5. SHARED CACHE STORES

Data Grid cache stores can be local to a given node or shared across all nodes in the cluster. By default, cache stores are local (**shared="false"**).

- Local cache stores are unique to each node; for example, a file-based cache store that persists data to the host filesystem.  
Local cache stores can fetch state and purge on startup to avoid loading stale entries from persistent storage.

- Shared cache stores allow multiple nodes to use the same persistent storage; for example, a JDBC cache store that allows multiple nodes to access the same database. Shared cache stores ensure that only the primary owner write to persistent storage, instead of backup nodes performing write operations for every modification.



### IMPORTANT

Never configure shared cache stores to fetch state and purge on startup. Fetching state with shared cache stores results in performance issues and longer cluster start times. Purging deletes data, which is not typically the desired behavior for persistent storage.

#### Local cache store

```
<persistence>
  <store shared="false"
    fetch-state="true"
    purge="true"/>
</persistence>
```

#### Shared cache store

```
<persistence>
  <store shared="true"
    fetch-state="false"
    purge="false"/>
</persistence>
```

#### Additional resources

- [Data Grid Configuration Schema](#)

## 6.6. TRANSACTIONS WITH PERSISTENT CACHE STORES

Data Grid supports transactional operations with JDBC-based cache stores only. To configure caches as transactional, you set **transactional=true** to keep data in persistent storage synchronized with data in memory.

For all other cache stores, Data Grid does not enlist cache loaders in transactional operations. This can result in data inconsistency if transactions succeed in modifying data in memory but do not completely apply changes to data in the cache store. In these cases manual recovery is not possible with cache stores.

## 6.7. GLOBAL PERSISTENT LOCATION

Data Grid preserves global state so that it can restore cluster topology and cached data after restart.

#### Remote caches

Data Grid Server saves cluster state to the **\$RHDG\_HOME/server/data** directory.



## IMPORTANT

You should never delete or modify the **server/data** directory or its content. Data Grid restores cluster state from this directory when you restart your server instances.

Changing the default configuration or directly modifying the **server/data** directory can cause unexpected behavior and lead to data loss.

### Embedded caches

Data Grid defaults to the **user.dir** system property as the global persistent location. In most cases this is the directory where your application starts.

For clustered embedded caches, such as replicated or distributed, you should always enable and configure a global persistent location to restore cluster topology.

You should never configure an absolute path for a file-based cache store that is outside the global persistent location. If you do, Data Grid writes the following exception to logs:

```
ISPN000558: "The store location 'foo' is not a child of the global persistent location 'bar'"
```

### 6.7.1. Configuring the global persistent location

Enable and configure the location where Data Grid stores global state for clustered embedded caches.



## NOTE

Data Grid Server enables global persistence and configures a default location. You should not disable global persistence or change the default configuration for remote caches.

### Prerequisites

- Add Data Grid to your project.

### Procedure

1. Enable global state in one of the following ways:
  - Add the **global-state** element to your Data Grid configuration.
  - Call the **globalState().enable()** methods in the **GlobalConfigurationBuilder** API.
2. Define whether the global persistent location is unique to each node or shared between the cluster.

Location type	Configuration
Unique to each node	<b>persistent-location</b> element or <b>persistentLocation()</b> method
Shared between the cluster	<b>shared-persistent-location</b> element or <b>sharedPersistentLocation(String)</b> method

3. Set the path where Data Grid stores cluster state.

For example, file-based cache stores the path is a directory on the host filesystem.

Values can be:

- Absolute and contain the full location including the root.
  - Relative to a root location.
4. If you specify a relative value for the path, you must also specify a system property that resolves to a root location.  
For example, on a Linux host system you set **global/state** as the path. You also set the **my.data** property that resolves to the **/opt/data** root location. In this case Data Grid uses **/opt/data/global/state** as the global persistent location.

## Global persistent location configuration

### XML

```
<infinispan>
  <cache-container>
    <global-state>
      <persistent-location path="global/state" relative-to="my.data"/>
    </global-state>
  </cache-container>
</infinispan>
```

### JSON

```
{
  "infinispan" : {
    "cache-container" : {
      "global-state": {
        "persistent-location" : {
          "path" : "global/state",
          "relative-to" : "my.data"
        }
      }
    }
  }
}
```

### YAML

```
cacheContainer:
  globalState:
    persistentLocation:
      path: "global/state"
      relativeTo : "my.data"
```

## GlobalConfigurationBuilder

```
new GlobalConfigurationBuilder().globalState()
    .enable()
    .persistentLocation("global/state", "my.data");
```

### Additional resources

- [Data Grid configuration schema](#)
- [org.infinispan.configuration.global.GlobalStateConfiguration](http://org.infinispan.configuration.global.GlobalStateConfiguration)

## 6.8. FILE-BASED CACHE STORES

File-based cache stores provide persistent storage on the local host filesystem where Data Grid is running. For clustered caches, file-based cache stores are unique to each Data Grid node.



### WARNING

Never use filesystem-based cache stores on shared file systems, such as an NFS or Samba share, because they do not provide file locking capabilities and data corruption can occur.

Additionally if you attempt to use transactional caches with shared file systems, unrecoverable failures can happen when writing to files during the commit phase.

### Soft-Index File Stores

**SoftIndexFileStore** is the default implementation for file-based cache stores and stores data in a set of append-only files.

When append-only files:

- Reach their maximum size, Data Grid creates a new file and starts writing to it.
- Reach the compaction threshold of less than 50% usage, Data Grid overwrites the entries to a new file and then deletes the old file.

### B+ trees

To improve performance, append-only files in a **SoftIndexFileStore** are indexed using a **B+ Tree** that can be stored both on disk and in memory. The in-memory index uses Java soft references to ensure it can be rebuilt if removed by Garbage Collection (GC) then requested again.

Because **SoftIndexFileStore** uses Java soft references to keep indexes in memory, it helps prevent out-of-memory exceptions. GC removes indexes before they consume too much memory while still falling back to disk.

You can configure any number of B+ trees with the **segments** attribute on the **index** element declaratively or with the **indexSegments()** method programmatically. By default Data Grid creates up to 16 B+ trees, which means there can be up to 16 indexes. Having multiple indexes prevents bottlenecks

from concurrent writes to an index and reduces the number of entries that Data Grid needs to keep in memory. As it iterates over a soft-index file store, Data Grid reads all entries in an index at the same time.

Each entry in the B+ tree is a node. By default, the size of each node is limited to 4096 bytes. **SoftIndexFileStore** throws an exception if keys are longer after serialization occurs.

### Segmentation

Soft-index file stores are always segmented.



#### NOTE

The **AdvancedStore.purgeExpired()** method is not implemented in **SoftIndexFileStore**.

### Single File Cache Stores



#### NOTE

Single file cache stores are now deprecated and planned for removal.

Single File cache stores, **SingleFileStore**, persist data to file. Data Grid also maintains an in-memory index of keys while keys and values are stored in the file.

Because **SingleFileStore** keeps an in-memory index of keys and the location of values, it requires additional memory, depending on the key size and the number of keys. For this reason, **SingleFileStore** is not recommended for use cases where the keys are larger or there can be a larger number of them.

In some cases, **SingleFileStore** can also become fragmented. If the size of values continually increases, available space in the single file is not used but the entry is appended to the end of the file. Available space in the file is used only if an entry can fit within it. Likewise, if you remove all entries from memory, the single file store does not decrease in size or become defragmented.

### Segmentation

Single file cache stores are segmented by default with a separate instance per segment, which results in multiple directories. Each directory is a number that represents the segment to which the data maps.

## 6.8.1. Configuring file-based cache stores

Add file-based cache stores to Data Grid to persist data on the host filesystem.

### Prerequisites

- Enable global state and configure a global persistent location if you are configuring embedded caches.

### Procedure

1. Add the **persistence** element to your cache configuration.
2. Optionally specify **true** as the value for the **passivation** attribute to write to the file-based cache store only when data is evicted from memory.
3. Include the **file-store** element and configure attributes as appropriate.



4. Specify **false** as the value for the **shared** attribute.  
File-based cache stores should always be unique to each Data Grid instance. If you want to use the same persistent across a cluster, configure shared storage such as a JDBC string-based cache store .
5. Configure the **index** and **data** elements to specify the location where Data Grid creates indexes and stores data.
6. Include the **write-behind** element if you want to configure the cache store with write-behind mode.

### File-based cache store configuration

#### XML

```
<distributed-cache>
  <persistence passivation="true">
    <file-store shared="false">
      <data path="data"/>
      <index path="index"/>
      <write-behind modification-queue-size="2048" />
    </file-store>
  </persistence>
</distributed-cache>
```

#### JSON

```
{
  "distributed-cache": {
    "persistence": {
      "passivation": true,
      "file-store" : {
        "shared": false,
        "data": {
          "path": "data"
        },
        "index": {
          "path": "index"
        },
        "write-behind": {
          "modification-queue-size": "2048"
        }
      }
    }
  }
}
```

#### YAML

```
distributedCache:
  persistence:
    passivation: "true"
  fileStore:
```

```

shared: "false"
data:
  path: "data"
index:
  path: "index"
writeBehind:
  modificationQueueSize: "2048"

```

### ConfigurationBuilder

```

ConfigurationBuilder builder = new ConfigurationBuilder();
builder.persistence().passivation(true)
    .addSoftIndexFileStore()
    .shared(false)
    .dataLocation("data")
    .indexLocation("index")
    .modificationQueueSize(2048);

```

## 6.8.2. Configuring single file cache stores

If required, you can configure Data Grid to create single file stores.



### IMPORTANT

Single file stores are deprecated. You should use soft-index file stores for better performance and data consistency in comparison with single file stores.

### Prerequisites

- Enable global state and configure a global persistent location if you are configuring embedded caches.

### Procedure

1. Add the **persistence** element to your cache configuration.
2. Optionally specify **true** as the value for the **passivation** attribute to write to the file-based cache store only when data is evicted from memory.
3. Include the **single-file-store** element.
4. Specify **false** as the value for the **shared** attribute.
5. Configure any other attributes as appropriate.
6. Include the **write-behind** element to configure the cache store as write behind instead of as write through.

### Single file cache store configuration

#### XML

```
<distributed-cache>
```

```

<persistence passivation="true">
  <single-file-store shared="false"
    preload="true"
    fetch-state="true"/>
</persistence>
</distributed-cache>

```

## JSON

```

{
  "distributed-cache": {
    "persistence" : {
      "passivation" : true,
      "single-file-store" : {
        "shared" : false,
        "preload" : true,
        "fetch-state" : true
      }
    }
  }
}

```

## YAML

```

distributedCache:
  persistence:
    passivation: "true"
    singleFileStore:
      shared: "false"
      preload: "true"
      fetchState: "true"

```

## ConfigurationBuilder

```

ConfigurationBuilder builder = new ConfigurationBuilder();
builder.persistence().passivation(true)
    .addStore(SingleFileStoreConfigurationBuilder.class)
    .shared(false)
    .preload(true)
    .fetchPersistentState(true);

```

## 6.9. JDBC CONNECTION FACTORIES

Data Grid provides different **ConnectionFactory** implementations that allow you to connect to databases. You use JDBC connections with SQL cache stores and JDBC string-based caches stores.

### Connection pools

Connection pools are suitable for standalone Data Grid deployments and are based on Agroal.

## XML

```

<distributed-cache>
  <persistence>
    <connection-pool connection-url="jdbc:h2:mem:infinispan;DB_CLOSE_DELAY=-1"
      username="sa"
      password="changeme"
      driver="org.h2.Driver"/>
  </persistence>
</distributed-cache>

```

## JSON

```

{
  "distributed-cache": {
    "persistence": {
      "connection-pool": {
        "connection-url": "jdbc:h2:mem:infinispan_string_based",
        "driver": "org.h2.Driver",
        "username": "sa",
        "password": "changeme"
      }
    }
  }
}

```

## YAML

```

distributedCache:
  persistence:
    connectionPool:
      connectionUrl: "jdbc:h2:mem:infinispan_string_based;DB_CLOSE_DELAY=-1"
      driver: org.h2.Driver
      username: sa
      password: changeme

```

## ConfigurationBuilder

```

ConfigurationBuilder builder = new ConfigurationBuilder();
builder.persistence()
  .connectionPool()
  .connectionUrl("jdbc:h2:mem:infinispan_string_based;DB_CLOSE_DELAY=-1")
  .username("sa")
  .driverClass("org.h2.Driver");

```

## Managed datasources

Datasource connections are suitable for managed environments such as application servers.

## XML

```

<distributed-cache>
  <persistence>
    <data-source jndi-url="java:/StringStoreWithManagedConnectionTest/DS" />
  </persistence>
</distributed-cache>

```

```

</persistence>
</distributed-cache>

```

## JSON

```

{
  "distributed-cache": {
    "persistence": {
      "data-source": {
        "jndi-url": "java:/StringStoreWithManagedConnectionTest/DS"
      }
    }
  }
}

```

## YAML

```

distributedCache:
  persistence:
    dataSource:
      jndiUrl: "java:/StringStoreWithManagedConnectionTest/DS"

```

## ConfigurationBuilder

```

ConfigurationBuilder builder = new ConfigurationBuilder();
builder.persistence()
    .dataSource()
    .jndiUrl("java:/StringStoreWithManagedConnectionTest/DS");

```

## Simple connections

Simple connection factories create database connections on a per invocation basis and are intended for use with test or development environments only.

## XML

```

<distributed-cache>
  <persistence>
    <simple-connection connection-url="jdbc:h2://localhost"
      username="sa"
      password="changeme"
      driver="org.h2.Driver"/>
  </persistence>
</distributed-cache>

```

## JSON

```

{
  "distributed-cache": {
    "persistence": {
      "simple-connection": {
        "connection-url": "jdbc:h2://localhost",

```

```

    "driver": "org.h2.Driver",
    "username": "sa",
    "password": "changeme"
  }
}
}
}

```

## YAML

```

distributedCache:
  persistence:
    simpleConnection:
      connectionUrl: "jdbc:h2://localhost"
      driver: org.h2.Driver
      username: sa
      password: changeme

```

## ConfigurationBuilder

```

ConfigurationBuilder builder = new ConfigurationBuilder();
builder.persistence()
  .simpleConnection()
  .connectionUrl("jdbc:h2://localhost")
  .driverClass("org.h2.Driver")
  .username("admin")
  .password("changeme");

```

## Additional resources

- [PooledConnectionFactoryConfigurationBuilder](#)
- [ManagedConnectionFactoryConfigurationBuilder](#)
- [SimpleConnectionFactoryConfigurationBuilder](#)

### 6.9.1. Configuring managed datasources

Create managed datasources as part of your Data Grid Server configuration to optimize connection pooling and performance for JDBC database connections. You can then specify the JDNI name of the managed datasources in your caches, which centralizes JDBC connection configuration for your deployment.

#### Prerequisites

- Copy database drivers to the **server/lib** directory in your Data Grid Server installation.

#### Procedure

1. Open your Data Grid Server configuration for editing.
2. Add a new **data-source** to the **data-sources** section.

3. Uniquely identify the datasource with the **name** attribute or field.
4. Specify a JNDI name for the datasource with the **jndi-name** attribute or field.

### TIP

You use the JNDI name to specify the datasource in your JDBC cache store configuration.

5. Set **true** as the value of the **statistics** attribute or field to enable statistics for the datasource through the **/metrics** endpoint.
6. Provide JDBC driver details that define how to connect to the datasource in the **connection-factory** section.
  - a. Specify the name of the database driver with the **driver** attribute or field.
  - b. Specify the JDBC connection url with the **url** attribute or field.
  - c. Specify credentials with the **username** and **password** attributes or fields.
  - d. Provide any other configuration as appropriate.
7. Define how Data Grid Server nodes pool and reuse connections with connection pool tuning properties in the **connection-pool** section.
8. Save the changes to your configuration.

### Verification

Use the Data Grid Command Line Interface (CLI) to test the datasource connection, as follows:

1. Start a CLI session.

```
bin/cli.sh
```

2. List all datasources and confirm the one you created is available.

```
server datasource ls
```

3. Test a datasource connection.

```
server datasource test my-datasource
```

### Managed datasource configuration

#### XML

```
<server xmlns="urn:infinispan:server:13.0">
  <data-sources>
    <!-- Defines a unique name for the datasource and JNDI name that you
         reference in JDBC cache store configuration.
         Enables statistics for the datasource, if required. -->
    <data-source name="ds"
      jndi-name="jdbc/postgres"
      statistics="true">
```

```

<!-- Specifies the JDBC driver that creates connections. -->
<connection-factory driver="org.postgresql.Driver"
    url="jdbc:postgresql://localhost:5432/postgres"
    username="postgres"
    password="changeme">
    <!-- Sets optional JDBC driver-specific connection properties. -->
    <connection-property name="name">value</connection-property>
</connection-factory>
<!-- Defines connection pool tuning properties. -->
<connection-pool initial-size="1"
    max-size="10"
    min-size="3"
    background-validation="1000"
    idle-removal="1"
    blocking-timeout="1000"
    leak-detection="10000"/>
</data-source>
</data-sources>
</server>

```

## JSON

```

{
  "server": {
    "data-sources": [{
      "name": "ds",
      "jndi-name": "jdbc/postgres",
      "statistics": true,
      "connection-factory": {
        "driver": "org.postgresql.Driver",
        "url": "jdbc:postgresql://localhost:5432/postgres",
        "username": "postgres",
        "password": "changeme",
        "connection-properties": {
          "name": "value"
        }
      }
    }],
    "connection-pool": {
      "initial-size": 1,
      "max-size": 10,
      "min-size": 3,
      "background-validation": 1000,
      "idle-removal": 1,
      "blocking-timeout": 1000,
      "leak-detection": 10000
    }
  }
}

```

## YAML

```

server:
  dataSources:

```



```

- name: ds
  jndiName: 'jdbc/postgres'
  statistics: true
  connectionFactory:
    driver: "org.postgresql.Driver"
    url: "jdbc:postgresql://localhost:5432/postgres"
    username: "postgres"
    password: "changeme"
  connectionProperties:
    name: value
  connectionPool:
    initialSize: 1
    maxSize: 10
    minSize: 3
    backgroundValidation: 1000
    idleRemoval: 1
    blockingTimeout: 1000
    leakDetection: 10000

```

### 6.9.1.1. Configuring caches with JNDI names

When you add a managed datasource to Data Grid Server you can add the JNDI name to a JDBC-based cache store configuration.

#### Prerequisites

- Configure Data Grid Server with a managed datasource.

#### Procedure

1. Open your cache configuration for editing.
2. Add the **data-source** element or field to the JDBC-based cache store configuration.
3. Specify the JNDI name of the managed datasource as the value of the **jndi-url** attribute.
4. Configure the JDBC-based cache stores as appropriate.
5. Save the changes to your configuration.

#### JNDI name in cache configuration

#### XML

```

<distributed-cache>
  <persistence>
    <jdbc:string-keyed-jdbc-store>
      <!-- Specifies the JNDI name of a managed datasource on Data Grid Server. -->
      <jdbc:data-source jndi-url="jdbc/postgres"/>
      <jdbc:string-keyed-table drop-on-exit="true" create-on-start="true" prefix="TBL">
        <jdbc:id-column name="ID" type="VARCHAR(255)"/>
        <jdbc:data-column name="DATA" type="BYTEA"/>
        <jdbc:timestamp-column name="TS" type="BIGINT"/>
        <jdbc:segment-column name="S" type="INT"/>
      </jdbc:string-keyed-table>
    </jdbc:string-keyed-jdbc-store>
  </persistence>
</distributed-cache>

```

```

    </jdbc:string-keyed-jdbc-store>
  </persistence>
</distributed-cache>

```

## JSON

```

{
  "distributed-cache": {
    "persistence": {
      "string-keyed-jdbc-store": {
        "data-source": {
          "jndi-url": "jdbc/postgres"
        },
        "string-keyed-table": {
          "prefix": "TBL",
          "drop-on-exit": true,
          "create-on-start": true,
          "id-column": {
            "name": "ID",
            "type": "VARCHAR(255)"
          },
          "data-column": {
            "name": "DATA",
            "type": "BYTEA"
          },
          "timestamp-column": {
            "name": "TS",
            "type": "BIGINT"
          },
          "segment-column": {
            "name": "S",
            "type": "INT"
          }
        }
      }
    }
  }
}

```

## YAML

```

distributedCache:
  persistence:
    stringKeyedJdbcStore:
      dataSource:
        jndi-url: "jdbc/postgres"
      stringKeyedTable:
        prefix: "TBL"
        dropOnExit: true
        createOnStart: true
        idColumn:
          name: "ID"
          type: "VARCHAR(255)"
        dataColumn:

```

```

name: "DATA"
type: "BYTEA"
timestampColumn:
name: "TS"
type: "BIGINT"
segmentColumn:
name: "S"
type: "INT"

```

### 6.9.1.2. Connection pool tuning properties

You can tune JDBC connection pools for managed datasources in your Data Grid Server configuration.

Property	Description
<b>initial-size</b>	Initial number of connections the pool should hold.
<b>max-size</b>	Maximum number of connections in the pool.
<b>min-size</b>	Minimum number of connections the pool should hold.
<b>blocking-timeout</b>	Maximum time in milliseconds to block while waiting for a connection before throwing an exception. This will never throw an exception if creating a new connection takes an inordinately long period of time. Default is <b>0</b> meaning that a call will wait indefinitely.
<b>background-validation</b>	Time in milliseconds between background validation runs. A duration of <b>0</b> means that this feature is disabled.
<b>validate-on-acquisition</b>	Connections idle for longer than this time, specified in milliseconds, are validated before being acquired (foreground validation). A duration of <b>0</b> means that this feature is disabled.
<b>idle-removal</b>	Time in minutes a connection has to be idle before it can be removed.
<b>leak-detection</b>	Time in milliseconds a connection has to be held before a leak warning.

### 6.9.2. Configuring JDBC connection pools with Agroal properties

You can use a properties file to configure pooled connection factories for JDBC string-based cache stores.

#### Procedure

1. Specify JDBC connection pool configuration with **org.infinispan.agroal.\*** properties, as in the following example:

```
org.infinispan.agroal.metricsEnabled=false

org.infinispan.agroal.minSize=10
org.infinispan.agroal.maxSize=100
org.infinispan.agroal.initialSize=20
org.infinispan.agroal.acquisitionTimeout_s=1
org.infinispan.agroal.validationTimeout_m=1
org.infinispan.agroal.leakTimeout_s=10
org.infinispan.agroal.reapTimeout_m=10

org.infinispan.agroal.metricsEnabled=false
org.infinispan.agroal.autoCommit=true
org.infinispan.agroal.jdbcTransactionIsolation=READ_COMMITTED
org.infinispan.agroal.jdbcUrl=jdbc:h2:mem:PooledConnectionFactoryTest;DB_CLOSE_DELAY=-1
org.infinispan.agroal.driverClassName=org.h2.Driver.class
org.infinispan.agroal.principal=sa
org.infinispan.agroal.credential=sa
```

2. Configure Data Grid to use your properties file with the **properties-file** attribute or the **PooledConnectionFactoryConfiguration.propertyFile()** method.

#### XML

```
<connection-pool properties-file="path/to/agroal.properties"/>
```

#### JSON

```
"persistence": {
  "connection-pool": {
    "properties-file": "path/to/agroal.properties"
  }
}
```

#### YAML

```
persistence:
  connectionPool:
    propertiesFile: path/to/agroal.properties
```

#### ConfigurationBuilder

```
.connectionPool().propertyFile("path/to/agroal.properties")
```

#### Additional resources

- [Agroal](#)

## 6.10. SQL CACHE STORES

SQL cache stores let you load Data Grid caches from existing database tables. Data Grid offers two types of SQL cache store:

### Table

Data Grid loads entries from a single database table.

### Query

Data Grid uses SQL queries to load entries from single or multiple database tables, including from sub-columns within those tables, and perform insert, update, and delete operations.

### TIP

Visit the code tutorials to try a SQL cache store in action. See the [Persistence code tutorial with remote caches](#).

Both SQL table and query stores:

- Allow read and write operations to persistent storage.
- Can be read-only and act as a cache loader.
- Support keys and values that correspond to a single database column or a composite of multiple database columns.

For composite keys and values, you must provide Data Grid with Protobuf schema (**.proto** files) that describe the keys and values. With Data Grid Server you can add schema through the Data Grid Console or Command Line Interface (CLI) with the **schema** command.

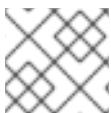

### NOTE

SQL cache stores do not support expiration or segmentation.

### Additional resources

- [DatabaseType Enum lists supported database dialects](#)
- [Data Grid SQL store configuration reference](#)

### 6.10.1. Data types for keys and values

Data Grid loads keys and values from columns in database tables via SQL cache stores, automatically using the appropriate data types. The following **CREATE** statement adds a table named "books" that has two columns, **isbn** and **title**:

#### Database table with two columns

```
CREATE TABLE books (
  isbn NUMBER(13),
  title varchar(120)
  PRIMARY KEY(isbn)
);
```

When you use this table with a SQL cache store, Data Grid adds an entry to the cache using the **isbn** column as the key and the **title** column as the value.

### Additional resources

- [Data Grid SQL store configuration reference](#)

#### 6.10.1.1. Composite keys and values

You can use SQL stores with database tables that contain composite primary keys or composite values.

To use composite keys or values, you must provide Data Grid with Protobuf schema that describe the data types. You must also add **schema** configuration to your SQL store and specify the message names for keys and values.

### TIP

Data Grid recommends generating Protobuf schema with the ProtoStream processor. You can then upload your Protobuf schema for remote caches through the Data Grid Console, CLI, or REST API.

### Composite values

The following database table holds a composite value of the **title** and **author** columns:

```
CREATE TABLE books (
  isbn NUMBER(13),
  title varchar(120),
  author varchar(80)
  PRIMARY KEY(isbn)
);
```

Data Grid adds an entry to the cache using the **isbn** column as the key. For the value, Data Grid requires a Protobuf schema that maps the **title** column and the **author** columns:

```
package library;

message books_value {
  optional string title = 1;
  optional string author = 2;
}
```

### Composite keys and values

The following database table holds a composite primary key and a composite value, with two columns each:

```
CREATE TABLE books (
  isbn NUMBER(13),
  reprint INT,
  title varchar(120),
  author varchar(80)
  PRIMARY KEY(isbn, reprint)
);
```

For both the key and the value, Data Grid requires a Protobuf schema that maps the columns to keys and values:

```

package library;

message books_key {
  required string isbn = 1;
  required int32 reprint = 2;
}

message books_value {
  optional string title = 1;
  optional string author = 2;
}

```

### Additional resources

- [Cache encoding and marshalling: Generate Protobuf schema and register them with Data Grid](#)
- [Data Grid SQL store configuration reference](#)

### 6.10.1.2. Embedded keys

Protobuf schema can include keys within values, as in the following example:

#### Protobuf schema with an embedded key

```

package library;

message books_key {
  required string isbn = 1;
  required int32 reprint = 2;
}

message books_value {
  required string isbn = 1;
  required string reprint = 2;
  optional string title = 3;
  optional string author = 4;
}

```

To use embedded keys, you must include the **embedded-key="true"** attribute or **embeddedKey(true)** method in your SQL store configuration.

### 6.10.1.3. SQL types to Protobuf types

The following table contains default mappings of SQL data types to Protobuf data types:

SQL type	Protobuf type
<b>int4</b>	<b>int32</b>
<b>int8</b>	<b>int64</b>
<b>float4</b>	<b>float</b>

SQL type	Protobuf type
<b>float8</b>	<b>double</b>
<b>numeric</b>	<b>double</b>
<b>bool</b>	<b>bool</b>
<b>char</b>	<b>string</b>
<b>varchar</b>	<b>string</b>
<b>text, tinytext, mediumtext, longtext</b>	<b>string</b>
<b>bytea, tinyblob, blob, mediumblob, longblob</b>	<b>bytes</b>

#### Additional resources

- [Cache encoding and marshalling](#)

### 6.10.2. Loading Data Grid caches from database tables

Add a SQL table cache store to your configuration if you want Data Grid to load data from a database table. When it connects to the database, Data Grid uses metadata from the table to detect column names and data types. Data Grid also automatically determines which columns in the database are part of the primary key.

#### Prerequisites

- Have JDBC connection details.  
You can add JDBC connection factories directly to your cache configuration. For remote caches in production environments, you should add managed datasources to Data Grid Server configuration and specify the JNDI name in the cache configuration.
- Generate Protobuf schema for any composite keys or composite values and register your schemas with Data Grid.

#### TIP

Data Grid recommends generating Protobuf schema with the ProtoStream processor. For remote caches, you can register your schemas by adding them through the Data Grid Console, CLI, or REST API.

#### Procedure

1. Add database drivers to your Data Grid deployment.
  - Remote caches: Copy database drivers to the **server/lib** directory in your Data Grid Server installation.
  - Embedded caches: Add the **infinispan-cachestore-sql** dependency to your **pom** file.



```
<dependency>
  <groupId>org.infinispan</groupId>
  <artifactId>infinispan-cache-store-sql</artifactId>
</dependency>
```

2. Open your Data Grid configuration for editing.
3. Add a SQL table cache store.

### Declarative

```
table-jdbc-store xmlns="urn:infinispan:config:store:sql:13.0"
```

### Programmatic

```
persistence().addStore(TableJdbcStoreConfigurationBuilder.class)
```

4. Specify the database dialect with either **dialect=""** or **dialect()**, for example **dialect="H2"** or **dialect="postgres"**.
5. Configure the SQL cache store with the properties you require, for example:
  - To use the same cache store across your cluster, set **shared="true"** or **shared(true)**.
  - To create a read only cache store, set **read-only="true"** or **.ignoreModifications(true)**.
6. Name the database table that loads the cache with **table-name="<database\_table\_name>"** or **table.name("<database\_table\_name>")**.
7. Add the **schema** element or the **.schemaJdbcConfigurationBuilder()** method and add Protobuf schema configuration for composite keys or values.
  - a. Specify the package name with the **package** attribute or **package()** method.
  - b. Specify composite values with the **message-name** attribute or **messageName()** method.
  - c. Specify composite keys with the **key-message-name** attribute or **keyMessageName()** method.
  - d. Set a value of **true** for the **embedded-key** attribute or **embeddedKey()** method if your schema includes keys within values.
8. Save the changes to your configuration.

### SQL table store configuration

The following example loads a distributed cache from a database table named "books" using composite values defined in a Protobuf schema:

### XML

```
<distributed-cache>
  <persistence>
    <table-jdbc-store xmlns="urn:infinispan:config:store:sql:13.0"
      dialect="H2"
```

```

        shared="true"
        table-name="books">
<schema message-name="books_value"
    package="library"/>
</table-jdbc-store>
</persistence>
</distributed-cache>

```

## JSON

```

{
  "distributed-cache": {
    "persistence": {
      "table-jdbc-store": {
        "dialect": "H2",
        "shared": "true",
        "table-name": "books",
        "schema": {
          "message-name": "books_value",
          "package": "library"
        }
      }
    }
  }
}

```

## YAML

```

distributedCache:
  persistence:
    tableJdbcStore:
      dialect: "H2"
      shared: "true"
      tableName: "books"
      schema:
        messageName: "books_value"
        package: "library"

```

## ConfigurationBuilder

```

ConfigurationBuilder builder = new ConfigurationBuilder();
builder.persistence().addStore(TableJdbcStoreConfigurationBuilder.class)
    .dialect(DatabaseType.H2)
    .shared("true")
    .tableName("books")
    .schemaJdbcConfigurationBuilder()
    .messageName("books_value")
    .packageName("library");

```

## Additional resources

- [Cache encoding and marshalling: Generate Protobuf schema and register them with Data Grid](#)

- [Persistence code tutorial with remote caches](#)
- [JDBC connection factories](#)
- [DatabaseType Enum lists supported database dialects](#)
- [Data Grid SQL store configuration reference](#)

### 6.10.3. Using SQL queries to load data and perform operations

SQL query cache stores let you load caches from multiple database tables, including from sub-columns in database tables, and perform insert, update, and delete operations.

#### Prerequisites

- Have JDBC connection details.  
You can add JDBC connection factories directly to your cache configuration. For remote caches in production environments, you should add managed datasources to Data Grid Server configuration and specify the JNDI name in the cache configuration.
- Generate Protobuf schema for any composite keys or composite values and register your schemas with Data Grid.

#### TIP

Data Grid recommends generating Protobuf schema with the ProtoStream processor. For remote caches, you can register your schemas by adding them through the Data Grid Console, CLI, or REST API.

#### Procedure

1. Add database drivers to your Data Grid deployment.
  - Remote caches: Copy database drivers to the **server/lib** directory in your Data Grid Server installation.
  - Embedded caches: Add the **infinispan-cachestore-sql** dependency to your **pom** file and make sure database drivers are on your application classpath.

```
<dependency>
  <groupId>org.infinispan</groupId>
  <artifactId>infinispan-cachestore-sql</artifactId>
</dependency>
```

2. Open your Data Grid configuration for editing.
3. Add a SQL query cache store.

#### Declarative

```
query-jdbc-store xmlns="urn:infinispan:config:store:jdbc:13.0"
```

#### Programmatic

■

```
persistence().addStore(QueriesJdbcStoreConfigurationBuilder.class)
```

4. Specify the database dialect with either **dialect=""** or **dialect()**, for example **dialect="H2"** or **dialect="postgres"**.
5. Configure the SQL cache store with the properties you require, for example:
  - To use the same cache store across your cluster, set **shared="true"** or **shared(true)**.
  - To create a read only cache store, set **read-only="true"** or **.ignoreModifications(true)**.
6. Define SQL query statements that load caches with data and modify database tables with the **queries** element or the **queries()** method.

Query statement	Description
<b>SELECT</b>	Loads a single entry into caches. You can use wildcards but must specify parameters for keys. You can use labelled expressions.
<b>SELECT ALL</b>	Loads multiple entries into caches. You can use the * wildcard if the number of columns returned match the key and value columns. You can use labelled expressions.
<b>SIZE</b>	Counts the number of entries in the cache.
<b>DELETE</b>	Deletes a single entry from the cache.
<b>DELETE ALL</b>	Deletes all entries from the cache.
<b>UPSERT</b>	Modifies entries in the cache.

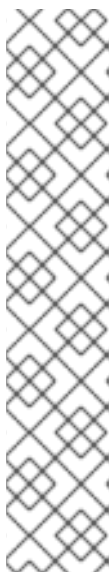

## NOTE

**DELETE**, **DELETE ALL**, and **UPSERT** statements do not apply to read only cache stores but are required if cache stores allow modifications.

Parameters in **DELETE** statements must match parameters in **SELECT** statements exactly.

Variables in **UPSERT** statements must have the same number of uniquely named variables that **SELECT** and **SELECT ALL** statements return. For example, if **SELECT** returns **foo** and **bar** this statement must take only **:foo** and **:bar** as variables. However you can apply the same named variable more than once in a statement.

SQL queries can include **JOIN**, **ON**, and any other clauses that the database supports.

7. Add the **schema** element or the **.schemaJdbcConfigurationBuilder()** method and add Protobuf schema configuration for composite keys or values.

• Specify the package name with the **package** attribute or **package()** method

- a. Specify the package name with the **package** attribute or **package()** method.
  - b. Specify composite values with the **message-name** attribute or **messageName()** method.
  - c. Specify composite keys with the **key-message-name** attribute or **keyMessageName()** method.
  - d. Set a value of **true** for the **embedded-key** attribute or **embeddedKey()** method if your schema includes keys within values.
8. Save the changes to your configuration.

### Additional resources

- [Cache encoding and marshalling: Generate Protobuf schema and register them with Data Grid](#)
- [Persistence code tutorial with remote caches](#)
- [JDBC connection factories](#)
- [DatabaseType Enum lists supported database dialects](#)
- [Data Grid SQL store configuration reference](#)

#### 6.10.3.1. SQL query store configuration

This section provides an example configuration for a SQL query cache store that loads a distributed cache with data from two database tables: "person" and "address".

#### SQL statements

SQL data definition language (DDL) statements for the "person" and "address" tables are as follows:

#### SQL statement for the "person" table

```
CREATE TABLE Person (
  name VARCHAR(255) NOT NULL,
  picture VARBINARY(255),
  sex VARCHAR(255),
  birthdate TIMESTAMP,
  accepted_tos BOOLEAN,
  notused VARCHAR(255),
  PRIMARY KEY (name)
);
```

#### SQL statement for the "address" table

```
CREATE TABLE Address (
  name VARCHAR(255) NOT NULL,
  street VARCHAR(255),
  city VARCHAR(255),
  zip INT,
  PRIMARY KEY (name)
);
```

#### Protobuf schemas

Protobuf schema for the "person" and "address" tables are as follows:

### Protobuf schema for the "person" table

```
package com.example

enum Sex {
  FEMALE = 1;
  MALE = 2;
}

message Person {
  optional string name = 1;
  optional Address address = 2;
  optional bytes picture = 3;
  optional Sex sex = 4;
  optional fixed64 birthDate = 5 [default = 0];
  optional bool accepted_tos = 6 [default = false];
}
```

### Protobuf schema for the "address" table

```
package com.example

message Address {
  optional string street = 1;
  optional string city = 2 [default = "San Jose"];
  optional int32 zip = 3 [default = 0];
}
```

### Cache configuration

The following example loads a distributed cache from the "person" and "address" tables using a SQL query that includes a **JOIN** clause:

### XML

```
<distributed-cache>
  <persistence>
    <query-jdbc-store xmlns="urn:infinispan:config:store:jdbc:13.0"
      dialect="POSTGRES"
      shared="true">
      <queries key-columns="name">
        <select-single>SELECT t1.name, t1.picture, t1.sex, t1.birthdate, t1.accepted_tos, t2.street,
t2.city, t2.zip FROM Person t1 JOIN Address t2 ON t1.name = t2.name WHERE t1.name =
:name</select-single>
        <select-all>SELECT t1.name, t1.picture, t1.sex, t1.birthdate, t1.accepted_tos, t2.street, t2.city,
t2.zip FROM Person t1 JOIN Address t2 ON t1.name = t2.name</select-all>
        <delete-single>DELETE FROM Person t1 WHERE t1.name = :name; DELETE FROM Address
t2 where t2.name = :name</delete-single>
        <delete-all>DELETE FROM Person; DELETE FROM Address</delete-all>
        <upsert>INSERT INTO Person (name, picture, sex, birthdate, accepted_tos) VALUES (:name,
:picture, :sex, :birthdate, :accepted_tos); INSERT INTO Address(name, street, city, zip) VALUES
(:name, :street, :city, :zip)</upsert>
```

```

<size>SELECT COUNT(*) FROM Person</size>
</queries>
<schema message-name="Person"
  package="com.example"
  embedded-key="true"/>
</query-jdbc-store>
</persistence>
</distributed-cache>

```

## JSON

```

{
  "distributed-cache": {
    "persistence": {
      "query-jdbc-store": {
        "dialect": "POSTGRES",
        "shared": "true",
        "key-columns": "name",
        "queries": {
          "select-single": "SELECT t1.name, t1.picture, t1.sex, t1.birthdate, t1.accepted_tos, t2.street,
t2.city, t2.zip FROM Person t1 JOIN Address t2 ON t1.name = t2.name WHERE t1.name = :name",
          "select-all": "SELECT t1.name, t1.picture, t1.sex, t1.birthdate, t1.accepted_tos, t2.street, t2.city,
t2.zip FROM Person t1 JOIN Address t2 ON t1.name = t2.name",
          "delete-single": "DELETE FROM Person t1 WHERE t1.name = :name; DELETE FROM
Address t2 where t2.name = :name",
          "delete-all": "DELETE FROM Person; DELETE FROM Address",
          "upsert": "INSERT INTO Person (name, picture, sex, birthdate, accepted_tos) VALUES
(:name, :picture, :sex, :birthdate, :accepted_tos); INSERT INTO Address(name, street, city, zip)
VALUES (:name, :street, :city, :zip)",
          "size": "SELECT COUNT(*) FROM Person"
        },
        "schema": {
          "message-name": "Person",
          "package": "com.example",
          "embedded-key": "true"
        }
      }
    }
  }
}

```

## YAML

```

distributedCache:
  persistence:
    queryJdbcStore:
      dialect: "POSTGRES"
      shared: "true"
      keyColumns: "name"
      queries:
        selectSingle: "SELECT t1.name, t1.picture, t1.sex, t1.birthdate, t1.accepted_tos, t2.street,
t2.city, t2.zip FROM Person t1 JOIN Address t2 ON t1.name = t2.name WHERE t1.name = :name"
        selectAll: "SELECT t1.name, t1.picture, t1.sex, t1.birthdate, t1.accepted_tos, t2.street, t2.city,
t2.zip FROM Person t1 JOIN Address t2 ON t1.name = t2.name"

```

```

deleteSingle: "DELETE FROM Person t1 WHERE t1.name = :name; DELETE FROM Address t2
where t2.name = :name"
deleteAll: "DELETE FROM Person; DELETE FROM Address"
upsert: "INSERT INTO Person (name, picture, sex, birthdate, accepted_tos) VALUES (:name,
:picture, :sex, :birthdate, :accepted_tos); INSERT INTO Address(name, street, city, zip) VALUES
(:name, :street, :city, :zip)"
size: "SELECT COUNT(*) FROM Person"
schema:
  messageName: "Person"
  package: "com.example"
  embeddedKey: "true"

```

## ConfigurationBuilder

```

ConfigurationBuilder builder = new ConfigurationBuilder();
builder.persistence().addStore(QueriesJdbcStoreConfigurationBuilder.class)
    .dialect(DatabaseType.POSTGRES)
    .shared("true")
    .keyColumns("name")
    .queriesJdbcConfigurationBuilder()
        .select("SELECT t1.name, t1.picture, t1.sex, t1.birthdate, t1.accepted_tos, t2.street, t2.city,
t2.zip FROM Person t1 JOIN Address t2 ON t1.name = t2.name WHERE t1.name = :name")
        .selectAll("SELECT t1.name, t1.picture, t1.sex, t1.birthdate, t1.accepted_tos, t2.street, t2.city,
t2.zip FROM Person t1 JOIN Address t2 ON t1.name = t2.name")
        .delete("DELETE FROM Person t1 WHERE t1.name = :name; DELETE FROM Address t2
where t2.name = :name")
        .deleteAll("DELETE FROM Person; DELETE FROM Address")
        .upsert("INSERT INTO Person (name, picture, sex, birthdate, accepted_tos) VALUES (:name,
:picture, :sex, :birthdate, :accepted_tos); INSERT INTO Address(name, street, city, zip) VALUES
(:name, :street, :city, :zip)")
        .size("SELECT COUNT(*) FROM Person")
    .schemaJdbcConfigurationBuilder()
        .messageName("Person")
        .packageName("com.example")
        .embeddedKey(true);

```

## Additional resources

- [Data Grid SQL store configuration reference](#)

### 6.10.4. SQL cache store troubleshooting

Find out about common issues and errors with SQL cache stores and how to troubleshoot them.

**ISPN008064:** No primary keys found for table <table\_name>, check case sensitivity

Data Grid logs this message in the following cases:

- The database table does not exist.
- The database table name is case sensitive and needs to be either all lower case or all upper case, depending on the database provider.
- The database table does not have any primary keys defined.



To resolve this issue you should:

1. Check your SQL cache store configuration and ensure that you specify the name of an existing table.
2. Ensure that the database table name conforms to an case sensitivity requirements.
3. Ensure that your database tables have primary keys that uniquely identify the appropriate rows.

## 6.11. JDBC STRING-BASED CACHE STORES

JDBC String-Based cache stores, **JdbcStringBasedStore**, use JDBC drivers to load and store values in the underlying database.

JDBC String-Based cache stores:

- Store each entry in its own row in the table to increase throughput for concurrent loads.
- Use a simple one-to-one mapping that maps each key to a **String** object using the **key-to-string-mapper** interface. Data Grid provides a default implementation, **DefaultTwoWayKey2StringMapper**, that handles primitive types.

In addition to the data table used to store cache entries, the store also creates a **\_META** table for storing metadata. This table is used to ensure that any existing database content is compatible with the current Data Grid version and configuration.



### NOTE

By default Data Grid shares are not stored, which means that all nodes in the cluster write to the underlying store on each update. If you want operations to write to the underlying database once only, you must configure JDBC store as shared.

### Segmentation

**JdbcStringBasedStore** uses segmentation by default and requires a column in the database table to represent the segments to which entries belong.

### Additional resources

- [DatabaseType Enum lists supported database dialects](#)

### 6.11.1. Configuring JDBC string-based cache stores

Configure Data Grid caches with JDBC string-based cache stores that can connect to databases.

#### Prerequisites

- Remote caches: Copy database drivers to the **server/lib** directory in your Data Grid Server installation.
- Embedded caches: Add the **infinispan-cachestore-jdbc** dependency to your **pom** file.

```
<dependency>
<groupId>org.infinispan</groupId>
```

```
<artifactId>infinispan-cachestore-jdbc</artifactId>
</dependency>
```

## Procedure

1. Create a JDBC string-based cache store configuration in one of the following ways:
  - Declaratively, add the **persistence** element or field then add **string-keyed-jdbc-store** with the following schema namespace:

```
xmlns="urn:infinispan:config:store:jdbc:13.0"
```

- Programmatically, add the following methods to your **ConfigurationBuilder**:

```
persistence().addStore(JdbcStringBasedStoreConfigurationBuilder.class)
```

2. Specify the dialect of the database with either the **dialect** attribute or the **dialect()** method.
3. Configure any properties for the JDBC string-based cache store as appropriate. For example, specify if the cache store is shared with multiple cache instances with either the **shared** attribute or the **shared()** method.
4. Add a JDBC connection factory so that Data Grid can connect to the database.
5. Add a database table that stores cache entries.

## JDBC string-based cache store configuration

### XML

```
<distributed-cache>
  <persistence>
    <string-keyed-jdbc-store xmlns="urn:infinispan:config:store:jdbc:13.0"
      dialect="H2">
      <connection-pool connection-url="jdbc:h2:mem:infinispan"
        username="sa"
        password="changeme"
        driver="org.h2.Driver"/>
      <string-keyed-table create-on-start="true"
        prefix="ISPN_STRING_TABLE">
        <id-column name="ID_COLUMN"
          type="VARCHAR(255)" />
        <data-column name="DATA_COLUMN"
          type="BINARY" />
        <timestamp-column name="TIMESTAMP_COLUMN"
          type="BIGINT" />
        <segment-column name="SEGMENT_COLUMN"
          type="INT"/>
      </string-keyed-table>
    </string-keyed-jdbc-store>
  </persistence>
</distributed-cache>
```

### JSON

```

{
  "distributed-cache": {
    "persistence": {
      "string-keyed-jdbc-store": {
        "dialect": "H2",
        "string-keyed-table": {
          "prefix": "ISPN_STRING_TABLE",
          "create-on-start": true,
          "id-column": {
            "name": "ID_COLUMN",
            "type": "VARCHAR(255)"
          },
          "data-column": {
            "name": "DATA_COLUMN",
            "type": "BINARY"
          },
          "timestamp-column": {
            "name": "TIMESTAMP_COLUMN",
            "type": "BIGINT"
          },
          "segment-column": {
            "name": "SEGMENT_COLUMN",
            "type": "INT"
          }
        },
        "connection-pool": {
          "connection-url": "jdbc:h2:mem:infinispan",
          "driver": "org.h2.Driver",
          "username": "sa",
          "password": "changeme"
        }
      }
    }
  }
}

```

## YAML

```

distributedCache:
  persistence:
    stringKeyedJdbcStore:
      dialect: "H2"
      stringKeyedTable:
        prefix: "ISPN_STRING_TABLE"
        createOnStart: true
        idColumn:
          name: "ID_COLUMN"
          type: "VARCHAR(255)"
        dataColumn:
          name: "DATA_COLUMN"
          type: "BINARY"
        timestampColumn:
          name: "TIMESTAMP_COLUMN"
          type: "BIGINT"
        segmentColumn:

```

```

    name: "SEGMENT_COLUMN"
    type: "INT"
  connectionPool:
    connectionString: "jdbc:h2:mem:infinispan"
    driver: "org.h2.Driver"
    username: "sa"
    password: "changeme"

```

### ConfigurationBuilder

```

ConfigurationBuilder builder = new ConfigurationBuilder();
builder.persistence().addStore(JdbcStringBasedStoreConfigurationBuilder.class)
    .dialect(DatabaseType.H2)
    .table()
    .dropOnExit(true)
    .createOnStart(true)
    .tableNamePrefix("ISPN_STRING_TABLE")
    .idColumnName("ID_COLUMN").idColumnType("VARCHAR(255)")
    .dataColumnName("DATA_COLUMN").dataColumnType("BINARY")
    .timestampColumnName("TIMESTAMP_COLUMN").timestampColumnType("BIGINT")
    .segmentColumnName("SEGMENT_COLUMN").segmentColumnType("INT")
    .connectionPool()
    .connectionUrl("jdbc:h2:mem:infinispan")
    .username("sa")
    .password("changeme")
    .driverClass("org.h2.Driver");

```

### Additional resources

- [JDBC connection factories](#)

## 6.12. ROCKSDB CACHE STORES

RocksDB provides key-value filesystem-based storage with high performance and reliability for highly concurrent environments.

RocksDB cache stores, **RocksDBStore**, use two databases. One database provides a primary cache store for data in memory; the other database holds entries that Data Grid expires from memory.

**Table 6.1. Configuration parameters**

Parameter	Description
<b>location</b>	Specifies the path to the RocksDB database that provides the primary cache store. If you do not set the location, it is automatically created. Note that the path must be relative to the global persistent location.

Parameter	Description
<b>expiredLocation</b>	Specifies the path to the RocksDB database that provides the cache store for expired data. If you do not set the location, it is automatically created. Note that the path must be relative to the global persistent location.
<b>expiryQueueSize</b>	Sets the size of the in-memory queue for expiring entries. When the queue reaches the size, Data Grid flushes the expired into the RocksDB cache store.
<b>clearThreshold</b>	Sets the maximum number of entries before deleting and re-initializing ( <b>re-init</b> ) the RocksDB database. For smaller size cache stores, iterating through all entries and removing each one individually can provide a faster method.

## Tuning parameters

You can also specify the following RocksDB tuning parameters:

- **compressionType**
- **blockSize**
- **cacheSize**

## Configuration properties

Optionally set properties in the configuration as follows:

- Prefix properties with **database** to adjust and tune RocksDB databases.
- Prefix properties with **data** to configure the column families in which RocksDB stores your data.

```
<property name="database.max_background_compactions">2</property>
<property name="data.write_buffer_size">64MB</property>
<property
name="data.compression_per_level">kNoCompression:kNoCompression:kNoCompression:kSnappyCo
mpression:kZSTD:kZSTD</property>
```

## Segmentation

**RocksDBStore** supports segmentation and creates a separate column family per segment. Segmented RocksDB cache stores improve lookup performance and iteration but slightly lower performance of write operations.



### NOTE

You should not configure more than a few hundred segments. RocksDB is not designed to have an unlimited number of column families. Too many segments also significantly increases cache store start time.

## RocksDB cache store configuration

### XML

```
<local-cache>
  <persistence>
    <rocksdb-store xmlns="urn:infinispan:config:store:rocksdb:13.0"
      path="rocksdb/data">
      <expiration path="rocksdb/expired"/>
    </rocksdb-store>
  </persistence>
</local-cache>
```

### JSON

```
{
  "local-cache": {
    "persistence": {
      "rocksdb-store": {
        "path": "rocksdb/data",
        "expiration": {
          "path": "rocksdb/expired"
        }
      }
    }
  }
}
```

### YAML

```
localCache:
  persistence:
    rocksdbStore:
      path: "rocksdb/data"
      expiration:
        path: "rocksdb/expired"
```

### ConfigurationBuilder

```
Configuration cacheConfig = new ConfigurationBuilder().persistence()
  .addStore(RocksDBStoreConfigurationBuilder.class)
  .build();
EmbeddedCacheManager cacheManager = new DefaultCacheManager(cacheConfig);

Cache<String, User> usersCache = cacheManager.getCache("usersCache");
usersCache.put("raysang", new User(...));
```

### ConfigurationBuilder with properties

```
Properties props = new Properties();
props.put("database.max_background_compactions", "2");
```

```
props.put("data.write_buffer_size", "512MB");
```

```
Configuration cacheConfig = new ConfigurationBuilder().persistence()
    .addStore(RocksDBStoreConfigurationBuilder.class)
    .location("rocksdb/data")
    .expiredLocation("rocksdb/expired")
    .properties(props)
    .build();
```

## Reference

- [RocksDB cache store configuration schema](#)
- [RocksDBStore](#)
- [RocksDBStoreConfiguration](#)
- [rocksdb.org](#)
- [RocksDB Tuning Guide](#)

## 6.13. REMOTE CACHE STORES

Remote cache stores, **RemoteStore**, use the Hot Rod protocol to store data on Data Grid clusters.



### NOTE

If you configure remote cache stores as shared you cannot preload data. In other words if **shared="true"** in your configuration then you must set **preload="false"**.

## Segmentation

**RemoteStore** supports segmentation and can publish keys and entries by segment, which makes bulk operations more efficient. However, segmentation is available only with Data Grid Hot Rod protocol version 2.3 or later.



### WARNING

When you enable segmentation for **RemoteStore**, it uses the number of segments that you define in your Data Grid server configuration.

If the source cache is segmented and uses a different number of segments than **RemoteStore**, then incorrect values are returned for bulk operations. In this case, you should disable segmentation for **RemoteStore**.

## Remote cache store configuration

### XML

```

<distributed-cache>
  <persistence>
    <remote-store xmlns="urn:infinispan:config:store:remote:13.0"
      cache="mycache"
      raw-values="true">
      <remote-server host="one"
        port="12111" />
      <remote-server host="two" />
      <connection-pool max-active="10"
        exhausted-action="CREATE_NEW" />
    </remote-store>
  </persistence>
</distributed-cache>

```

## JSON

```

{
  "distributed-cache": {
    "remote-store": {
      "cache": "mycache",
      "raw-values": "true",
      "remote-server": [
        {
          "host": "one",
          "port": "12111"
        },
        {
          "host": "two"
        }
      ],
      "connection-pool": {
        "max-active": "10",
        "exhausted-action": "CREATE_NEW"
      }
    }
  }
}

```

## YAML

```

distributedCache:
  remoteStore:
    cache: "mycache"
    rawValues: "true"
    remoteServer:
      - host: "one"
        port: "12111"
      - host: "two"
    connectionPool:
      maxActive: "10"
      exhaustedAction: "CREATE_NEW"

```

## ConfigurationBuilder



```

ConfigurationBuilder b = new ConfigurationBuilder();
b.persistence().addStore(RemoteStoreConfigurationBuilder.class)
    .fetchPersistentState(false)
    .ignoreModifications(false)
    .purgeOnStartup(false)
    .remoteCacheName("mycache")
    .rawValues(true)
.addServer()
    .host("one").port(12111)
    .addServer()
    .host("two")
    .connectionPool()
    .maxActive(10)
    .exhaustedAction(ExhaustedAction.CREATE_NEW)
    .async().enable();

```

## Reference

- [Remote cache store configuration schema](#)
- [RemoteStore](#)
- [RemoteStoreConfigurationBuilder](#)

## 6.14. JPA CACHE STORES

JPA (Java Persistence API) cache stores, **JpaStore**, use formal schema to persist data.

Other applications can then read from persistent storage to load data from Data Grid. However, other applications should not use persistent storage concurrently with Data Grid.

When using JPA cache stores, you should take the following into consideration:

- Keys should be the ID of the entity. Values should be the entity object.
- Only a single **@Id** or **@EmbeddedId** annotation is allowed.
- Auto-generated IDs with the **@GeneratedValue** annotation are not supported.
- All entries are stored as immortal.
- JPA cache stores do not support segmentation.



### NOTE

You should use JPA cache stores with embedded Data Grid caches only.

## JPA cache store configuration

### XML

```

<local-cache name="vehicleCache">
  <persistence passivation="false">
    <jpa-store xmlns="urn:infinispan:config:store:jpa:13.0"

```

```

    persistence-unit="org.infinispan.persistence.jpa.configurationTest"
    entity-class="org.infinispan.persistence.jpa.entity.Vehicle">
  />
</persistence>
</local-cache>

```

## ConfigurationBuilder

```

Configuration cacheConfig = new ConfigurationBuilder().persistence()
    .addStore(JpaStoreConfigurationBuilder.class)
    .persistenceUnitName("org.infinispan.loaders.jpa.configurationTest")
    .entityClass(User.class)
    .build();

```

## Configuration parameters

Declarative	Programmatic	Description
<b>persistence-unit</b>	<b>persistenceUnitName</b>	Specifies the JPA persistence unit name in the JPA configuration file, <b>persistence.xml</b> , that contains the JPA entity class.
<b>entity-class</b>	<b>entityClass</b>	Specifies the fully qualified JPA entity class name that is expected to be stored in this cache. Only one class is allowed.

## Additional resources

- [JPA cache store configuration schema](#)
- [JpaStore](#)
- [JpaStoreConfiguration](#)

### 6.14.1. JPA cache store example

This section provides an example for using JPA cache stores.

#### Prerequisites

- Configure Data Grid to marshall your JPA entities.

#### Procedure

1. Define a persistence unit "myPersistenceUnit" in **persistence.xml**.

```

<persistence-unit name="myPersistenceUnit">
  <!-- Persistence configuration goes here. -->
</persistence-unit>

```

2. Create a user entity class.

```
@Entity
public class User implements Serializable {
    @Id
    private String username;
    private String firstName;
    private String lastName;

    ...
}
```

3. Configure a cache named "usersCache" with a JPA cache store. Then you can configure a cache "usersCache" to use JPA Cache Store, so that when you put data into the cache, the data would be persisted into the database based on JPA configuration.

```
EmbeddedCacheManager cacheManager = ...;

Configuration cacheConfig = new ConfigurationBuilder().persistence()
    .addStore(JpaStoreConfigurationBuilder.class)
    .persistenceUnitName("org.infinispan.loaders.jpa.configurationTest")
    .entityClass(User.class)
    .build();
cacheManager.defineCache("usersCache", cacheConfig);

Cache<String, User> usersCache = cacheManager.getCache("usersCache");
usersCache.put("raysang", new User(...));
```

- Caches that use a JPA cache store can store one type of data only, as in the following example:

```
Cache<String, User> usersCache = cacheManager.getCache("myJPACache");
// Cache is configured for the User entity class
usersCache.put("username", new User());
// Cannot configure caches to use another entity class with JPA cache stores
Cache<Integer, Teacher> teachersCache = cacheManager.getCache("myJPACache");
teachersCache.put(1, new Teacher());
// The put request does not work for the Teacher entity class
```

- The **@EmbeddedId** annotation allows you to use composite keys, as in the following example:

```
@Entity
public class Vehicle implements Serializable {
    @EmbeddedId
    private VehicleId id;
    private String color; ...
}

@Embeddable
public class VehicleId implements Serializable
{
    private String state;
```

```
private String licensePlate;
...
}
```

### Additional resources

- [Cache Encoding and Marshalling](#)

## 6.15. CLUSTER CACHE LOADERS

**ClusterCacheLoader** retrieves data from other Data Grid cluster members but does not persist data. In other words, **ClusterCacheLoader** is not a cache store.



### WARNING

**ClusterLoader** is deprecated and planned for removal in a future version.

**ClusterCacheLoader** provides a non-blocking partial alternative to state transfer.

**ClusterCacheLoader** fetches keys from other nodes on demand if those keys are not available on the local node, which is similar to lazily loading cache content.

The following points also apply to **ClusterCacheLoader**:

- Preloading does not take effect (**preload=true**).
- Fetching persistent state is not supported (**fetch-state=true**).
- Segmentation is not supported.

### Cluster cache loader configuration

#### XML

```
<distributed-cache>
  <persistence>
    <cluster-loader preload="true" remote-timeout="500"/>
  </persistence>
</distributed-cache>
```

#### JSON

```
{
  "distributed-cache": {
    "persistence": {
      "cluster-loader": {
        "preload": true,
        "remote-timeout": "500"
      }
    }
  }
}
```

```

    }
  }
}

```

## YAML

```

distributedCache:
  persistence:
    clusterLoader:
      preload: "true"
      remoteTimeout: "500"

```

## ConfigurationBuilder

```

ConfigurationBuilder b = new ConfigurationBuilder();
b.persistence()
  .addClusterLoader()
  .remoteCallTimeout(500);

```

## Additional resources

- [Data Grid configuration schema](#)
- [ClusterLoader](#)
- [ClusterLoaderConfiguration](#)

## 6.16. CREATING CUSTOM CACHE STORE IMPLEMENTATIONS

You can create custom cache stores through the Data Grid persistent SPI.

### 6.16.1. Data Grid Persistence SPI

The Data Grid Service Provider Interface (SPI) enables read and write operations to external storage through the **NonBlockingStore** interface and has the following features:

#### Portability across JCache-compliant vendors

Data Grid maintains compatibility between the **NonBlockingStore** interface and the **JSR-107** JCache specification by using an adapter that handles blocking code.

#### Simplified transaction integration

Data Grid automatically handles locking so your implementations do not need to coordinate concurrent access to persistent stores. Depending on the locking mode you use, concurrent writes to the same key generally do not occur. However, you should expect operations on the persistent storage to originate from multiple threads and create implementations to tolerate this behavior.

#### Parallel iteration

Data Grid lets you iterate over entries in persistent stores with multiple threads in parallel.

#### Reduced serialization resulting in less CPU usage

Data Grid exposes stored entries in a serialized format that can be transmitted remotely. For this reason, Data Grid does not need to deserialize entries that it retrieves from persistent storage and then serialize again when writing to the wire.

## Additional resources

- [Persistence SPI](#)
- [NonBlockingStore](#)
- [JSR-107](#)

### 6.16.2. Creating cache stores

Create custom cache stores with implementations of the **NonBlockingStore** API.

#### Procedure

1. Implement the appropriate Data Grid persistent SPIs.
2. Annotate your store class with the **@ConfiguredBy** annotation if it has a custom configuration.
3. Create a custom cache store configuration and builder if desired.
  - a. Extend **AbstractStoreConfiguration** and **AbstractStoreConfigurationBuilder**.
  - b. Optionally add the following annotations to your store Configuration class to ensure that your custom configuration builder parses your cache store configuration from XML:
    - **@ConfigurationFor**
    - **@BuiltBy**
 If you do not add these annotations, then **CustomStoreConfigurationBuilder** parses the common store attributes defined in **AbstractStoreConfiguration** and any additional elements are ignored.



#### NOTE

If a configuration does not declare the **@ConfigurationFor** annotation, a warning message is logged when Data Grid initializes the cache.

### 6.16.3. Examples of custom cache store configuration

The following are examples show how to configure Data Grid with custom cache store implementations:

#### XML

```
<distributed-cache>
  <persistence>
    <store class="org.infinispan.persistence.example.MyInMemoryStore" />
  </persistence>
</distributed-cache>
```

#### JSON

```
{
  "distributed-cache": {
    "persistence" : {
```

```

    "store" : {
      "class" : "org.infinispan.persistence.example.MyInMemoryStore"
    }
  }
}
}
}

```

## YAML

```

distributedCache:
  persistence:
    store:
      class: "org.infinispan.persistence.example.MyInMemoryStore"

```

## ConfigurationBuilder

```

Configuration config = new ConfigurationBuilder()
    .persistence()
    .addStore(CustomStoreConfigurationBuilder.class)
    .build();

```

### 6.16.4. Deploying custom cache stores

To use your cache store implementation with Data Grid Server, you must provide it with a JAR file.

#### Prerequisites

- Stop Data Grid Server if it is running. Data Grid loads JAR files at startup only.

#### Procedure

1. Package your custom cache store implementation in a JAR file.
2. Add your JAR file to the **server/lib** directory of your Data Grid Server installation.

## 6.17. MIGRATING DATA BETWEEN CACHE STORES

Data Grid provides a utility to migrate data from one cache store to another.

### 6.17.1. Cache store migrator

Data Grid provides the **StoreMigrator.java** utility that recreates data for the latest Data Grid cache store implementations.

**StoreMigrator** takes a cache store from a previous version of Data Grid as source and uses a cache store implementation as target.

When you run **StoreMigrator**, it creates the target cache with the cache store type that you define using the **EmbeddedCacheManager** interface. **StoreMigrator** then loads entries from the source store into memory and then puts them into the target cache.

**StoreMigrator** also lets you migrate data from one type of cache store to another. For example, you can migrate from a JDBC string-based cache store to a RocksDB cache store.

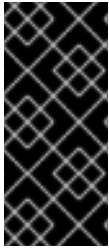

## IMPORTANT

**StoreMigrator** cannot migrate data from segmented cache stores to:

- Non-segmented cache store.
- Segmented cache stores that have a different number of segments.

### 6.17.2. Getting the cache store migrator

**StoreMigrator** is available as part of the Data Grid tools library, **infinispan-tools**, and is included in the Maven repository.

#### Procedure

- Configure your **pom.xml** for **StoreMigrator** as follows:

```
<?xml version="1.0" encoding="UTF-8"?>
<project xmlns="http://maven.apache.org/POM/4.0.0"
  xmlns:xsi="http://www.w3.org/2001/XMLSchema-instance"
  xsi:schemaLocation="http://maven.apache.org/POM/4.0.0
http://maven.apache.org/xsd/maven-4.0.0.xsd">
  <modelVersion>4.0.0</modelVersion>

  <groupId>org.infinispan.example</groupId>
  <artifactId>jdbc-migrator-example</artifactId>
  <version>1.0-SNAPSHOT</version>

  <dependencies>
    <dependency>
      <groupId>org.infinispan</groupId>
      <artifactId>infinispan-tools</artifactId>
    </dependency>
    <!-- Additional dependencies -->
  </dependencies>

  <build>
    <plugins>
      <plugin>
        <groupId>org.codehaus.mojo</groupId>
        <artifactId>exec-maven-plugin</artifactId>
        <version>1.2.1</version>
        <executions>
          <execution>
            <goals>
              <goal>java</goal>
            </goals>
          </execution>
        </executions>
        <configuration>
          <mainClass>org.infinispan.tools.store.migrator.StoreMigrator</mainClass>
          <arguments>
```



```

    <argument>path/to/migrator.properties</argument>
  </arguments>
</configuration>
</plugin>
</plugins>
</build>
</project>

```

### 6.17.3. Configuring the cache store migrator

Set properties for source and target cache stores in a **migrator.properties** file.

#### Procedure

1. Create a **migrator.properties** file.
2. Configure the source cache store in **migrator.properties**.
  - a. Prepend all configuration properties with **source.** as in the following example:

```

source.type=SOFT_INDEX_FILE_STORE
source.cache_name=myCache
source.location=/path/to/source/sifs
source.version=<version>

```

3. Configure the target cache store in **migrator.properties**.
  - a. Prepend all configuration properties with **target.** as in the following example:

```

target.type=SINGLE_FILE_STORE
target.cache_name=myCache
target.location=/path/to/target/sfs.dat

```

#### 6.17.3.1. Configuration properties for the cache store migrator

Configure source and target cache stores in a **StoreMigrator** properties.

**Table 6.2. Cache Store Type Property**

Property	Description	Required/Optional
----------	-------------	-------------------

Property	Description	Required/Optional
<b>type</b>	<p>Specifies the type of cache store type for a source or target.</p> <p><b>.type=JDBC_STRING</b></p> <p><b>.type=JDBC_BINARY</b></p> <p><b>.type=JDBC_MIXED</b></p> <p><b>.type=LEVELDB</b></p> <p><b>.type=ROCKSDB</b></p> <p><b>.type=SINGLE_FILE_STORE</b></p> <p><b>.type=SOFT_INDEX_FILE_STORE</b></p> <p><b>.type=JDBC_MIXED</b></p>	Required

Table 6.3. Common Properties

Property	Description	Example Value	Required/Optional
<b>cache_name</b>	Names the cache that the store backs.	<b>.cache_name=myCache</b>	Required
<b>segment_count</b>	<p>Specifies the number of segments for target cache stores that can use segmentation.</p> <p>The number of segments must match <b>clustering.hash.num Segments</b> in the Data Grid configuration.</p> <p>In other words, the number of segments for a cache store must match the number of segments for the corresponding cache. If the number of segments is not the same, Data Grid cannot read data from the cache store.</p>	<b>.segment_count=256</b>	Optional

Table 6.4. JDBC Properties

Property	Description	Required/Optional
<b>dialect</b>	Specifies the dialect of the underlying database.	Required
<b>version</b>	Specifies the marshaller version for source cache stores. Set one of the following values:  * <b>8</b> for Data Grid 7.2.x  * <b>9</b> for Data Grid 7.3.x  * <b>10</b> for Data Grid 8.0.x  * <b>11</b> for Data Grid 8.1.x  * <b>12</b> for Data Grid 8.2.x  * <b>13</b> for Data Grid 8.3.x	Required for source stores only.
<b>marshaller.class</b>	Specifies a custom marshaller class.	Required if using custom marshallers.
<b>marshaller.externalizers</b>	Specifies a comma-separated list of custom <b>AdvancedExternalizer</b> implementations to load in this format: <b>[id]:&lt;Externalizer class&gt;</b>	Optional
<b>connection_pool.connection_url</b>	Specifies the JDBC connection URL.	Required
<b>connection_pool.driver_classes</b>	Specifies the class of the JDBC driver.	Required
<b>connection_pool.username</b>	Specifies a database username.	Required
<b>connection_pool.password</b>	Specifies a password for the database username.	Required
<b>db.major_version</b>	Sets the database major version.	Optional
<b>db.minor_version</b>	Sets the database minor version.	Optional
<b>db.disable_upsert</b>	Disables database upsert.	Optional
<b>db.disable_indexing</b>	Specifies if table indexes are created.	Optional

Property	Description	Required/Optional
<b>table.string.table_name_prefix</b>	Specifies additional prefixes for the table name.	Optional
<b>table.string.&lt;id data timestamp&gt;.name</b>	Specifies the column name.	Required
<b>table.string.&lt;id data timestamp&gt;.type</b>	Specifies the column type.	Required
<b>key_to_string_mapper</b>	Specifies the <b>TwoWayKey2StringMapper</b> class.	Optional



#### NOTE

To migrate from Binary cache stores in older Data Grid versions, change **table.string.\*** to **table.binary.\*** in the following properties:

- **source.table.binary.table\_name\_prefix**
- **source.table.binary.<id|data|timestamp>.name**
- **source.table.binary.<id|data|timestamp>.type**

```
# Example configuration for migrating to a JDBC String-Based cache store
target.type=STRING
target.cache_name=myCache
target.dialect=POSTGRES
target.marshaller.class=org.example.CustomMarshaller
target.marshaller.externalizers=25:Externalizer1,org.example.Externalizer2
target.connection_pool.connection_url=jdbc:postgresql:postgres
target.connection_pool.driver_class=org.postgresql.Driver
target.connection_pool.username=postgres
target.connection_pool.password=redhat
target.db.major_version=9
target.db.minor_version=5
target.db.disable_upsert=false
target.db.disable_indexing=false
target.table.string.table_name_prefix=tablePrefix
target.table.string.id.name=id_column
target.table.string.data.name=datum_column
target.table.string.timestamp.name=timestamp_column
target.table.string.id.type=VARCHAR
target.table.string.data.type=bytea
target.table.string.timestamp.type=BIGINT
target.key_to_string_mapper=org.infinispan.persistence.keymappers.
DefaultTwoWayKey2StringMapper
```

Table 6.5. RocksDB Properties

Property	Description	Required/Optional
<b>location</b>	Sets the database directory.	Required
<b>compression</b>	Specifies the compression type to use.	Optional

```
# Example configuration for migrating from a RocksDB cache store.
source.type=ROCKSDB
source.cache_name=myCache
source.location=/path/to/rocksdb/database
source.compression=SNAPPY
```

Table 6.6. SingleFileStore Properties

Property	Description	Required/Optional
<b>location</b>	Sets the directory that contains the cache store <b>.dat</b> file.	Required

```
# Example configuration for migrating to a Single File cache store.
target.type=SINGLE_FILE_STORE
target.cache_name=myCache
target.location=/path/to/sfs.dat
```

Table 6.7. SoftIndexFileStore Properties

Property	Description	Value
Required/Optional	<b>location</b>	Sets the database directory.
Required	<b>index_location</b>	Sets the database index directory.

```
# Example configuration for migrating to a Soft-Index File cache store.
target.type=SOFT_INDEX_FILE_STORE
target.cache_name=myCache
target.location=path/to/sifs/database
target.location=path/to/sifs/index
```

#### 6.17.4. Migrating Data Grid cache stores

Run **StoreMigrator** to migrate data from one cache store to another.

##### Prerequisites

- Get **infinispan-tools.jar**.
- Create a **migrator.properties** file that configures the source and target cache stores.

## Procedure

- If you build **infinispan-tools.jar** from source, do the following:
  1. Add **infinispan-tools.jar** and dependencies for your source and target databases, such as JDBC drivers, to your classpath.
  2. Specify **migrator.properties** file as an argument for **StoreMigrator**.
- If you pull **infinispan-tools.jar** from the Maven repository, run the following command:  
**mvn exec:java**

## CHAPTER 7. CONFIGURING DATA GRID TO HANDLE NETWORK PARTITIONS

Data Grid clusters can split into network partitions in which subsets of nodes become isolated from each other. This condition results in loss of availability or consistency for clustered caches. Data Grid automatically detects crashed nodes and resolves conflicts to merge caches back together.

### 7.1. SPLIT CLUSTERS AND NETWORK PARTITIONS

Network partitions are the result of error conditions in the running environment, such as when a network router crashes. When a cluster splits into partitions, nodes create a JGroups cluster view that includes only the nodes in that partition. This condition means that nodes in one partition can operate independently of nodes in the other partition.

#### Detecting a split

To automatically detect network partitions, Data Grid uses the **FD\_ALL** protocol in the default JGroups stack to determine when nodes leave the cluster abruptly.



#### NOTE

Data Grid cannot detect what causes nodes to leave abruptly. This can happen not only when there is a network failure but also for other reasons, such as when Garbage Collection (GC) pauses the JVM.

Data Grid suspects that nodes have crashed after the following number of milliseconds:

```
FD_ALL.timeout + FD_ALL.interval + VERIFY_SUSPECT.timeout +
GMS.view_ack_collection_timeout
```

When it detects that the cluster is split into network partitions, Data Grid uses a strategy for handling cache operations. Depending on your application requirements Data Grid can:

- Allow read and/or write operations for availability
- Deny read and write operations for consistency

#### Merging partitions together

To fix a split cluster, Data Grid merges the partitions back together. During the merge, Data Grid uses the **.equals()** method for values of cache entries to determine if any conflicts exist. To resolve any conflicts between replicas it finds on partitions, Data Grid uses a merge policy that you can configure.

#### 7.1.1. Data consistency in a split cluster

Network outages or errors that cause Data Grid clusters to split into partitions can result in data loss or consistency issues regardless of any handling strategy or merge policy.

#### Between the split and detection

If a write operation takes place on a node that is in a minor partition when a split occurs, and before Data Grid detects the split, that value is lost when Data Grid transfers state to that minor partition during the merge.

In the event that all partitions are in the **DEGRADED** mode that value is not lost because no state

transfer occurs but the entry can have an inconsistent value. For transactional caches write operations that are in progress when the split occurs can be committed on some nodes and rolled back on other nodes, which also results in inconsistent values.

During the split and the time that Data Grid detects it, it is possible to get stale reads from a cache in a minor partition that has not yet entered **DEGRADED** mode.

### During the merge

When Data Grid starts removing partitions nodes reconnect to the cluster with a series of merge events. Before this merge process completes it is possible that write operations on transactional caches succeed on some nodes but not others, which can potentially result in stale reads until the entries are updated.

## 7.2. CACHE AVAILABILITY AND DEGRADED MODE

To preserve data consistency, Data Grid can put caches into **DEGRADED** mode if you configure them to use either the **DENY\_READ\_WRITES** or **ALLOW\_READS** partition handling strategy.

Data Grid puts caches in a partition into **DEGRADED** mode when the following conditions are true:

- At least one segment has lost all owners.  
This happens when a number of nodes equal to or greater than the number of owners for a distributed cache have left the cluster.
- There is not a majority of nodes in the partition.  
A majority of nodes is any number greater than half the total number of nodes in the cluster from the most recent stable topology, which was the last time a cluster rebalancing operation completed successfully.

When caches are in **DEGRADED** mode, Data Grid:

- Allows read and write operations only if all replicas of an entry reside in the same partition.
- Denies read and write operations and throws an **AvailabilityException** if the partition does not include all replicas of an entry.

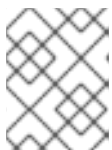

### NOTE

With the **ALLOW\_READS** strategy, Data Grid allows read operations on caches in **DEGRADED** mode.

**DEGRADED** mode guarantees consistency by ensuring that write operations do not take place for the same key in different partitions. Additionally **DEGRADED** mode prevents stale read operations that happen when a key is updated in one partition but read in another partition.

If all partitions are in **DEGRADED** mode then the cache becomes available again after merge only if the cluster contains a majority of nodes from the most recent stable topology and there is at least one replica of each entry. When the cluster has at least one replica of each entry, no keys are lost and Data Grid can create new replicas based on the number of owners during cluster rebalancing.

In some cases a cache in one partition can remain available while entering **DEGRADED** mode in another partition. When this happens the available partition continues cache operations as normal and Data Grid attempts to rebalance data across those nodes. To merge the cache together Data Grid always transfers state from the available partition to the partition in **DEGRADED** mode.



### 7.2.1. Degraded cache recovery example

This topic illustrates how Data Grid recovers from split clusters with caches that use the **DENY\_READ\_WRITES** partition handling strategy.

As an example, a Data Grid cluster has four nodes and includes a distributed cache with two replicas for each entry (**owners=2**). There are four entries in the cache, **k1**, **k2**, **k3** and **k4**.

With the **DENY\_READ\_WRITES** strategy, if the cluster splits into partitions, Data Grid allows cache operations only if all replicas of an entry are in the same partition.

In the following diagram, while the cache is split into partitions, Data Grid allows read and write operations for **k1** on partition 1 and **k4** on partition 2. Because there is only one replica for **k2** and **k3** on either partition 1 or partition 2, Data Grid denies read and write operations for those entries.

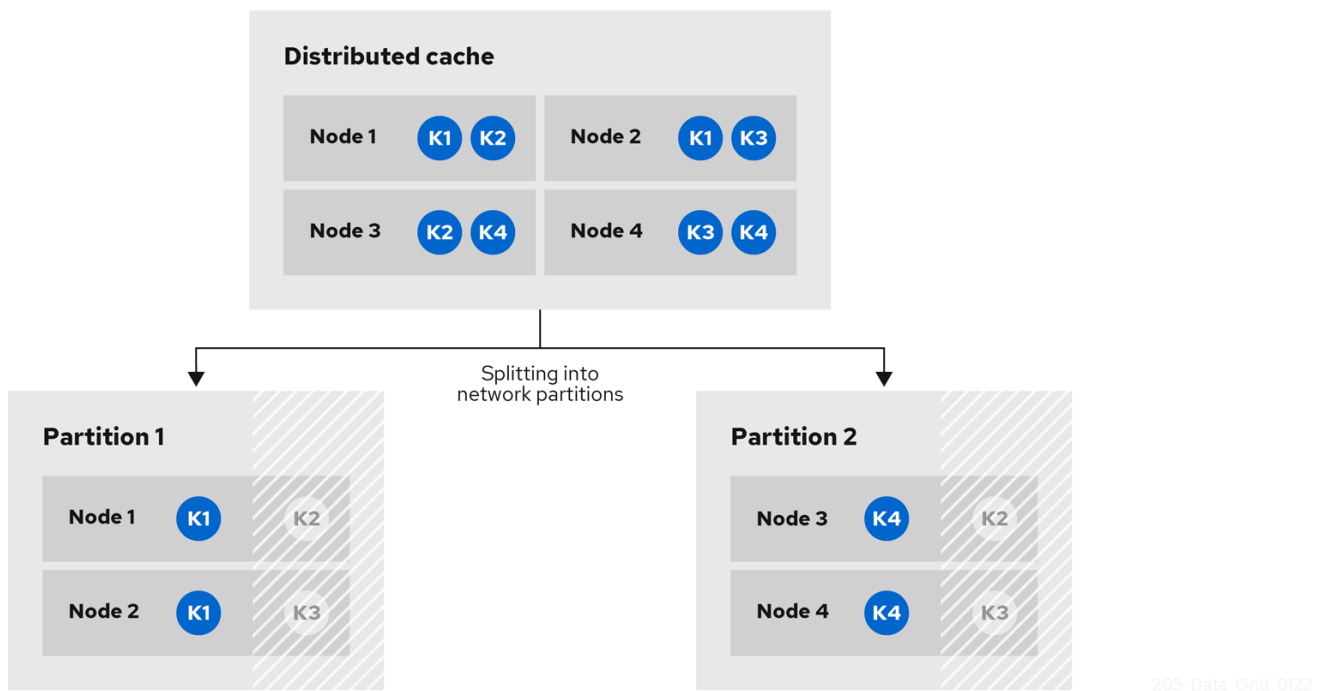

When network conditions allow the nodes to re-join the same cluster view, Data Grid merges the partitions without state transfer and restores normal cache operations.

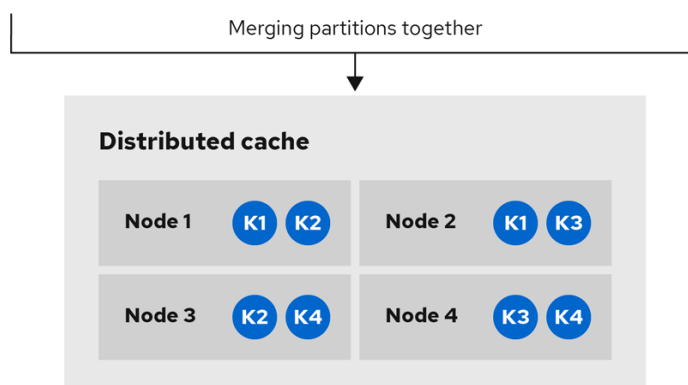

### 7.2.2. Verifying cache availability during network partitions

Determine if caches on Data Grid clusters are in **AVAILABLE** mode or **DEGRADED** mode during a network partition.

When Data Grid clusters split into partitions, nodes in those partitions can enter **DEGRADED** mode to guarantee data consistency. In **DEGRADED** mode clusters do not allow cache operations resulting in loss of availability.

## Procedure

Verify availability of clustered caches in network partitions in one of the following ways:

- Check Data Grid logs for **ISPN100011** messages that indicate if the cluster is available or if at least one cache is in **DEGRADED** mode.
- Get the availability of remote caches through the Data Grid Console or with the REST API.
  - Open the Data Grid Console in any browser, select the **Data Container** tab, and then locate the availability status in the **Health** column.
  - Retrieve cache health from the REST API.

```
GET /rest/v2/cache-managers/<cacheManagerName>/health
```

- Programmatically retrieve the availability of embedded caches with the **getAvailability()** method in the **AdvancedCache** API.

## Additional resources

- [REST API: Getting cluster health](#)
- [org.infinispan.AdvancedCache.getAvailability](#)
- [Enum AvailabilityMode](#)

### 7.2.3. Making caches available

Make caches available for read and write operations by forcing them out of **DEGRADED** mode.

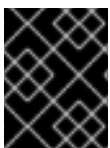

#### IMPORTANT

You should force clusters out of **DEGRADED** mode only if your deployment can tolerate data loss and inconsistency.

## Procedure

Make caches available in one of the following ways:

- Change the availability of remote caches with the REST API.

```
POST /v2/caches/<cacheName>?action=set-availability&availability=AVAILABLE
```

- Programmatically change the availability of embedded caches with the **AdvancedCache** API.

```
AdvancedCache ac = cache.getAdvancedCache();
// Retrieve cache availability
boolean available = ac.getAvailability() == AvailabilityMode.AVAILABLE;
```

```
// Make the cache available
if (!available) {
    ac.setAvailability(AvailabilityMode.AVAILABLE);
}
```

### Additional resources

- [REST API: Setting cache availability](#)
- [org.infinispan.AdvancedCache](#)

## 7.3. CONFIGURING PARTITION HANDLING

Configure Data Grid to use a partition handling strategy and merge policy so it can resolve split clusters when network issues occur. By default Data Grid uses a strategy that provides availability at the cost of lowering consistency guarantees for your data. When a cluster splits due to a network partition clients can continue to perform read and write operations on caches.

If you require consistency over availability, you can configure Data Grid to deny read and write operations while the cluster is split into partitions. Alternatively you can allow read operations and deny write operations. You can also specify custom merge policy implementations that configure Data Grid to resolve splits with custom logic tailored to your requirements.

### Prerequisites

- Have a Data Grid cluster where you can create either a replicated or distributed cache.



### NOTE

Partition handling configuration applies only to replicated and distributed caches.

### Procedure

1. Open your Data Grid configuration for editing.
2. Add partition handling configuration to your cache with either the **partition-handling** element or **partitionHandling()** method.
3. Specify a strategy for Data Grid to use when the cluster splits into partitions with the **when-split** attribute or **whenSplit()** method.  
The default partition handling strategy is **ALLOW\_READ\_WRITES** so caches remain available. If your use case requires data consistency over cache availability, specify the **DENY\_READ\_WRITES** strategy.
4. Specify a policy that Data Grid uses to resolve conflicting entries when merging partitions with the **merge-policy** attribute or **mergePolicy()** method.  
By default Data Grid does not resolve conflicts on merge.
5. Save the changes to your Data Grid configuration.

### Partition handling configuration

#### XML

```
<distributed-cache>
  <partition-handling when-split="DENY_READ_WRITES"
    merge-policy="PREFERRED_ALWAYS"/>
</distributed-cache>
```

## JSON

```
{
  "distributed-cache": {
    "partition-handling" : {
      "when-split": "DENY_READ_WRITES",
      "merge-policy": "PREFERRED_ALWAYS"
    }
  }
}
```

## YAML

```
distributedCache:
  partitionHandling:
    whenSplit: DENY_READ_WRITES
    mergePolicy: PREFERRED_ALWAYS
```

## ConfigurationBuilder

```
ConfigurationBuilder builder = new ConfigurationBuilder();
builder.clustering().cacheMode(CacheMode.DIST_SYNC)
    .partitionHandling()
    .whenSplit(PartitionHandling.DENY_READ_WRITES)
    .mergePolicy(MergePolicy.PREFERRED_NON_NULL);
```

## 7.4. PARTITION HANDLING STRATEGIES

Partition handling strategies control if Data Grid allows read and write operations when a cluster is split. The strategy you configure determines whether you get cache availability or data consistency.

Table 7.1. Partition handling strategies

Strategy	Description	Availability or consistency
<b>ALLOW_READ_WRITES</b>	Data Grid allows read and write operations on caches while a cluster is split into network partitions. Nodes in each partition remain available and function independently of each other. This is the default partition handling strategy.	Availability

Strategy	Description	Availability or consistency
<b>DENY_READ_WRITES</b>	Data Grid allows read and write operations only if all replicas of an entry are in the partition. If a partition does not include all replicas of an entry, Data Grid prevents cache operations for that entry.	Consistency
<b>ALLOW_READS</b>	Data Grid allows read operations for entries and prevents write operations unless the partition includes all replicas of an entry.	Consistency with read availability

## 7.5. MERGE POLICIES

Merge policies control how Data Grid resolves conflicts between replicas when bringing cluster partitions together. You can use one of the merge policies that Data Grid provides or you can create a custom implementation of the **EntryMergePolicy** API.

Table 7.2. Data Grid merge policies

Merge policy	Description	Considerations
<b>NONE</b>	Data Grid does not resolve conflicts when merging split clusters. This is the default merge policy.	Nodes drop segments for which they are not the primary owner, which can result in data loss.
<b>PREFERRED_ALWAYS</b>	Data Grid finds the value that exists on the majority of nodes in the cluster and uses it to resolve conflicts.	Data Grid could use stale values to resolve conflicts. Even if an entry is available the majority of nodes, the last update could happen on the minority partition.
<b>PREFERRED_NON_NULL</b>	Data Grid uses the first non-null value that it finds on the cluster to resolve conflicts.	Data Grid could restore deleted entries.
<b>REMOVE_ALL</b>	Data Grid removes any conflicting entries from the cache.	Results in loss of any entries that have different values when merging split clusters.

## 7.6. CONFIGURING CUSTOM MERGE POLICIES

Configure Data Grid to use custom implementations of the **EntryMergePolicy** API when handling network partitions.

## Prerequisites

- Implement the **EntryMergePolicy** API.

```
public class CustomMergePolicy implements EntryMergePolicy<String, String> {

    @Override
    public CacheEntry<String, String> merge(CacheEntry<String, String> preferredEntry,
        List<CacheEntry<String, String>> otherEntries) {
        // Decide which entry resolves the conflict

        return the_solved_CacheEntry;
    }
}
```

## Procedure

1. Deploy your merge policy implementation to Data Grid Server if you use remote caches.
  - a. Package your classes as a JAR file that includes a **META-INF/services/org.infinispan.conflict.EntryMergePolicy** file that contains the fully qualified class name of your merge policy.

```
# List implementations of EntryMergePolicy with the full qualified class name
org.example.CustomMergePolicy
```

- b. Add the JAR file to the **server/lib** directory.
2. Open your Data Grid configuration for editing.
  3. Configure cache encoding with the **encoding** element or **encoding()** method as appropriate. For remote caches, if you use only object metadata for comparison when merging entries then you can use **application/x-protostream** as the media type. In this case Data Grid returns entries to the **EntryMergePolicy** as **byte[]**.

If you require the object itself when merging conflicts then you should configure caches with the **application/x-java-object** media type. In this case you must deploy the relevant ProtoStream marshallers to Data Grid Server so it can perform **byte[]** to object transformations if clients use Protobuf encoding.

4. Specify your custom merge policy with the **merge-policy** attribute or **mergePolicy()** method as part of the partition handling configuration.
5. Save your changes.

## Custom merge policy configuration

### XML

```
<distributed-cache name="mycache">
  <partition-handling when-split="DENY_READ_WRITES"
    merge-policy="org.example.CustomMergePolicy"/>
</distributed-cache>
```

### JSON

```
{
  "distributed-cache": {
    "partition-handling" : {
      "when-split": "DENY_READ_WRITES",
      "merge-policy": "org.example.CustomMergePolicy"
    }
  }
}
```

## YAML

```
distributedCache:
  partitionHandling:
    whenSplit: DENY_READ_WRITES
    mergePolicy: org.example.CustomMergePolicy
```

## ConfigurationBuilder

```
ConfigurationBuilder builder = new ConfigurationBuilder();
builder.clustering().cacheMode(CacheMode.DIST_SYNC)
    .partitionHandling()
    .whenSplit(PartitionHandling.DENY_READ_WRITES)
    .mergePolicy(new CustomMergePolicy());
```

## Additional resources

- [org.infinispan.conflict.EntryMergePolicy](http://org.infinispan.conflict.EntryMergePolicy)

## 7.7. MANUALLY MERGING PARTITIONS IN EMBEDDED CACHES

Detect and resolve conflicting entries to manually merge embedded caches after network partitions occur.

### Procedure

- Retrieve the **ConflictManager** from the **EmbeddedCacheManager** to detect and resolve conflicting entries in a cache, as in the following example:

```
EmbeddedCacheManager manager = new DefaultCacheManager("example-config.xml");
Cache<Integer, String> cache = manager.getCache("testCache");
ConflictManager<Integer, String> crm =
    ConflictManagerFactory.get(cache.getAdvancedCache());

// Get all versions of a key
Map<Address, InternalCacheValue<String>> versions = crm.getAllVersions(1);

// Process conflicts stream and perform some operation on the cache
Stream<Map<Address, CacheEntry<Integer, String>>> conflicts = crm.getConflicts();
conflicts.forEach(map -> {
    CacheEntry<Integer, String> entry = map.values().iterator().next();
    Object conflictKey = entry.getKey();
    cache.remove(conflictKey);
});
```

```
});
```

```
// Detect and then resolve conflicts using the configured EntryMergePolicy  
crm.resolveConflicts();
```

```
// Detect and then resolve conflicts using the passed EntryMergePolicy instance  
crm.resolveConflicts((preferredEntry, otherEntries) -> preferredEntry);
```



#### NOTE

Although the **ConflictManager::getConflicts** stream is processed per entry, the underlying spliterator lazily loads cache entries on a per segment basis.



## CHAPTER 8. CONFIGURING USER ROLES AND PERMISSIONS

Authorization is a security feature that requires users to have certain permissions before they can access caches or interact with Data Grid resources. You assign roles to users that provide different levels of permissions, from read-only access to full, super user privileges.

### 8.1. SECURITY AUTHORIZATION

Data Grid authorization secures your deployment by restricting user access.

User applications or clients must belong to a role that is assigned with sufficient permissions before they can perform operations on Cache Managers or caches.

For example, you configure authorization on a specific cache instance so that invoking **Cache.get()** requires an identity to be assigned a role with read permission while **Cache.put()** requires a role with write permission.

In this scenario, if a user application or client with the **io** role attempts to write an entry, Data Grid denies the request and throws a security exception. If a user application or client with the **writer** role sends a write request, Data Grid validates authorization and issues a token for subsequent operations.

#### Identities

Identities are security Principals of type **java.security.Principal**. Subjects, implemented with the **javax.security.auth.Subject** class, represent a group of security Principals. In other words, a Subject represents a user and all groups to which it belongs.

#### Identities to roles

Data Grid uses role mappers so that security principals correspond to roles, which you assign one or more permissions.

The following image illustrates how security principals correspond to roles:

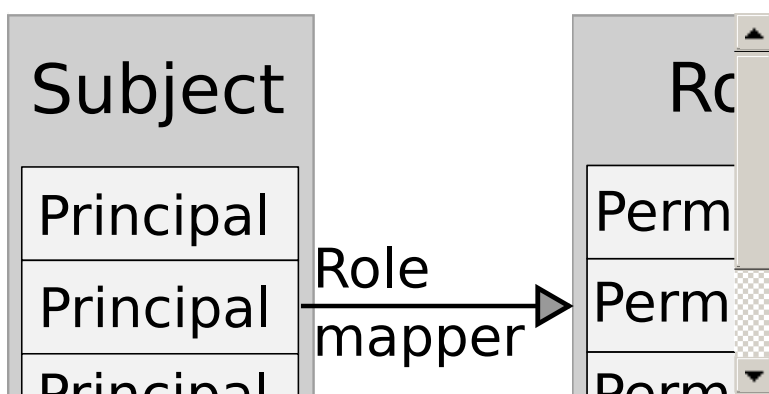

#### 8.1.1. User roles and permissions

Data Grid includes a default set of roles that grant users with permissions to access data and interact with Data Grid resources.

**ClusterRoleMapper** is the default mechanism that Data Grid uses to associate security principals to authorization roles.

**IMPORTANT**

**ClusterRoleMapper** matches principal names to role names. A user named **admin** gets **admin** permissions automatically, a user named **deployer** gets **deployer** permissions, and so on.

Role	Permissions	Description
<b>admin</b>	ALL	Superuser with all permissions including control of the Cache Manager lifecycle.
<b>deployer</b>	ALL_READ, ALL_WRITE, LISTEN, EXEC, MONITOR, CREATE	Can create and delete Data Grid resources in addition to <b>application</b> permissions.
<b>application</b>	ALL_READ, ALL_WRITE, LISTEN, EXEC, MONITOR	Has read and write access to Data Grid resources in addition to <b>observer</b> permissions. Can also listen to events and execute server tasks and scripts.
<b>observer</b>	ALL_READ, MONITOR	Has read access to Data Grid resources in addition to <b>monitor</b> permissions.
<b>monitor</b>	MONITOR	Can view statistics via JMX and the <b>metrics</b> endpoint.

**Reference**

- [org.infinispan.security.AuthorizationPermission Enumeration](#)
- [Data Grid configuration schema reference](#)

**8.1.2. Permissions**

Authorization roles have different permissions with varying levels of access to Data Grid. Permissions let you restrict user access to both Cache Managers and caches.

**8.1.2.1. Cache Manager permissions**

Permission	Function	Description
CONFIGURATION	<b>defineConfiguration</b>	Defines new cache configurations.
LISTEN	<b>addListener</b>	Registers listeners against a Cache Manager.

Permission	Function	Description
LIFECYCLE	<b>stop</b>	Stops the Cache Manager.
CREATE	<b>createCache, removeCache</b>	Create and remove container resources such as caches, counters, schemas, and scripts.
MONITOR	<b>getStats</b>	Allows access to JMX statistics and the <b>metrics</b> endpoint.
ALL	-	Includes all Cache Manager permissions.

### 8.1.2.2. Cache permissions

Permission	Function	Description
READ	<b>get, contains</b>	Retrieves entries from a cache.
WRITE	<b>put, putIfAbsent, replace, remove, evict</b>	Writes, replaces, removes, evicts data in a cache.
EXEC	<b>distexec, streams</b>	Allows code execution against a cache.
LISTEN	<b>addListener</b>	Registers listeners against a cache.
BULK_READ	<b>keySet, values, entrySet, query</b>	Executes bulk retrieve operations.
BULK_WRITE	<b>clear, putAll</b>	Executes bulk write operations.
LIFECYCLE	<b>start, stop</b>	Starts and stops a cache.

Permission	Function	Description
ADMIN	<b>getVersion, addInterceptor*, removeInterceptor, getInterceptorChain, getEvictionManager, getComponentRegistry, getDistributionManager, getAuthorizationManager, evict, getRpcManager, getCacheConfiguration, getCacheManager, getInvocationContextContainer, setAvailability, getDataContainer, getStats, getXAResource</b>	Allows access to underlying components and internal structures.
MONITOR	<b>getStats</b>	Allows access to JMX statistics and the <b>metrics</b> endpoint.
ALL	-	Includes all cache permissions.
ALL_READ	-	Combines the READ and BULK_READ permissions.
ALL_WRITE	-	Combines the WRITE and BULK_WRITE permissions.

#### Additional resources

- [Data Grid Security API](#)

### 8.1.3. Role mappers

Data Grid includes a **PrincipalRoleMapper** API that maps security Principals in a Subject to authorization roles that you can assign to users.

#### 8.1.3.1. Cluster role mappers

**ClusterRoleMapper** uses a persistent replicated cache to dynamically store principal-to-role mappings for the default roles and permissions.

By default uses the Principal name as the role name and implements **org.infinispan.security.MutableRoleMapper** which exposes methods to change role mappings at runtime.

- Java class: **org.infinispan.security.mappers.ClusterRoleMapper**
- Declarative configuration: **<cluster-role-mapper />**

#### 8.1.3.2. Identity role mappers

**IdentityRoleMapper** uses the Principal name as the role name.

- Java class: **org.infinispan.security.mappers.IdentityRoleMapper**
- Declarative configuration: **<identity-role-mapper />**

### 8.1.3.3. CommonName role mappers

**CommonNameRoleMapper** uses the Common Name (CN) as the role name if the Principal name is a Distinguished Name (DN).

For example this DN, **cn=managers,ou=people,dc=example,dc=com**, maps to the **managers** role.

- Java class: **org.infinispan.security.mappers.CommonRoleMapper**
- Declarative configuration: **<common-name-role-mapper />**

### 8.1.3.4. Custom role mappers

Custom role mappers are implementations of **org.infinispan.security.PrincipalRoleMapper**.

- Declarative configuration: **<custom-role-mapper class="my.custom.RoleMapper" />**

#### Additional resources

- [Data Grid Security API](#)
- [org.infinispan.security.PrincipalRoleMapper](#)

## 8.2. ACCESS CONTROL LIST (ACL) CACHE

Data Grid caches roles that you grant to users internally for optimal performance. Whenever you grant or deny roles to users, Data Grid flushes the ACL cache to ensure user permissions are applied correctly.

If necessary, you can disable the ACL cache or configure it with the **cache-size** and **cache-timeout** attributes.

#### XML

```
<infinispan>
  <cache-container name="acl-cache-configuration">
    <security cache-size="1000"
      cache-timeout="300000">
      <authorization/>
    </security>
  </cache-container>
</infinispan>
```

#### JSON

```
{
  "infinispan" : {
    "cache-container" : {
      "name" : "acl-cache-configuration",
```

```

    "security" : {
      "cache-size" : "1000",
      "cache-timeout" : "300000",
      "authorization" : {}
    }
  }
}
}
}

```

## YAML

```

infinispan:
  cacheContainer:
    name: "acl-cache-configuration"
  security:
    cache-size: "1000"
    cache-timeout: "300000"
    authorization: ~

```

## Additional resources

- [Data Grid configuration schema reference](#)

## 8.3. CUSTOMIZING ROLES AND PERMISSIONS

You can customize authorization settings in your Data Grid configuration to use role mappers with different combinations of roles and permissions.

### Procedure

1. Declare a role mapper and a set of custom roles and permissions in the Cache Manager configuration.
2. Configure authorization for caches to restrict access based on user roles.

### Custom roles and permissions configuration

#### XML

```

<infinispan>
  <cache-container name="custom-authorization">
    <security>
      <authorization>
        <!-- Declare a role mapper that associates a security principal
             to each role. -->
        <identity-role-mapper />
        <!-- Specify user roles and corresponding permissions. -->
        <role name="admin" permissions="ALL" />
        <role name="reader" permissions="READ" />
        <role name="writer" permissions="WRITE" />
        <role name="supervisor" permissions="READ WRITE EXEC"/>
      </authorization>
    </security>
  </cache-container>
</infinispan>

```

```

</security>
</cache-container>
</infinispan>

```

## JSON

```

{
  "infinispan" : {
    "cache-container" : {
      "name" : "custom-authorization",
      "security" : {
        "authorization" : {
          "identity-role-mapper" : null,
          "roles" : {
            "reader" : {
              "role" : {
                "permissions" : "READ"
              }
            },
            "admin" : {
              "role" : {
                "permissions" : "ALL"
              }
            },
            "writer" : {
              "role" : {
                "permissions" : "WRITE"
              }
            },
            "supervisor" : {
              "role" : {
                "permissions" : "READ WRITE EXEC"
              }
            }
          }
        }
      }
    }
  }
}

```

## YAML

```

infinispan:
  cacheContainer:
    name: "custom-authorization"
    security:
      authorization:
        identityRoleMapper: "null"
        roles:
          reader:
            role:
              permissions:
                - "READ"

```

```

admin:
  role:
  permissions:
    - "ALL"
writer:
  role:
  permissions:
    - "WRITE"
supervisor:
  role:
  permissions:
    - "READ"
    - "WRITE"
    - "EXEC"

```

## 8.4. CONFIGURING CACHES WITH SECURITY AUTHORIZATION

Use authorization in your cache configuration to restrict user access. Before they can read or write cache entries, or create and delete caches, users must have a role with a sufficient level of permission.

### Prerequisites

- Ensure the **authorization** element is included in the **security** section of the **cache-container** configuration.  
Data Grid enables security authorization in the Cache Manager by default and provides a global set of roles and permissions for caches.
- If necessary, declare custom roles and permissions in the Cache Manager configuration.

### Procedure

1. Open your cache configuration for editing.
2. Add the **authorization** element to caches to restrict user access based on their roles and permissions.
3. Save the changes to your configuration.

### Authorization configuration

The following configuration shows how to use implicit authorization configuration with default roles and permissions:

#### XML

```

<distributed-cache>
  <security>
    <!-- Inherit authorization settings from the cache-container. --> <authorization/>
  </security>
</distributed-cache>

```

#### JSON

```
{
```



```

"distributed-cache": {
  "security": {
    "authorization": {
      "enabled": true
    }
  }
}

```

#### YAML

```

distributedCache:
  security:
    authorization:
      enabled: true

```

### Custom roles and permissions

#### XML

```

<distributed-cache>
  <security>
    <authorization roles="admin supervisor"/>
  </security>
</distributed-cache>

```

#### JSON

```

{
  "distributed-cache": {
    "security": {
      "authorization": {
        "enabled": true,
        "roles": ["admin", "supervisor"]
      }
    }
  }
}

```

#### YAML

```

distributedCache:
  security:
    authorization:
      enabled: true
      roles: ["admin", "supervisor"]

```

## 8.5. DISABLING SECURITY AUTHORIZATION

In local development environments you can disable authorization so that users do not need roles and permissions. Disabling security authorization means that any user can access data and interact with Data Grid resources.

### Procedure

1. Open your Data Grid configuration for editing.
2. Remove any **authorization** elements from the **security** configuration for the Cache Manager.
3. Remove any **authorization** configuration from your caches.
4. Save the changes to your configuration.