



Red Hat OpenStack Platform 10

Bare Metal Provisioning

Install, Configure, and Use the Bare Metal Service (Ironic)

Red Hat OpenStack Platform 10 Bare Metal Provisioning

Install, Configure, and Use the Bare Metal Service (Ironic)

OpenStack Team
rhos-docs@redhat.com

Legal Notice

Copyright © 2020 Red Hat, Inc.

The text of and illustrations in this document are licensed by Red Hat under a Creative Commons Attribution–Share Alike 3.0 Unported license ("CC-BY-SA"). An explanation of CC-BY-SA is available at

<http://creativecommons.org/licenses/by-sa/3.0/>

. In accordance with CC-BY-SA, if you distribute this document or an adaptation of it, you must provide the URL for the original version.

Red Hat, as the licensor of this document, waives the right to enforce, and agrees not to assert, Section 4d of CC-BY-SA to the fullest extent permitted by applicable law.

Red Hat, Red Hat Enterprise Linux, the Shadowman logo, the Red Hat logo, JBoss, OpenShift, Fedora, the Infinity logo, and RHCE are trademarks of Red Hat, Inc., registered in the United States and other countries.

Linux[®] is the registered trademark of Linus Torvalds in the United States and other countries.

Java[®] is a registered trademark of Oracle and/or its affiliates.

XFS[®] is a trademark of Silicon Graphics International Corp. or its subsidiaries in the United States and/or other countries.

MySQL[®] is a registered trademark of MySQL AB in the United States, the European Union and other countries.

Node.js[®] is an official trademark of Joyent. Red Hat is not formally related to or endorsed by the official Joyent Node.js open source or commercial project.

The OpenStack[®] Word Mark and OpenStack logo are either registered trademarks/service marks or trademarks/service marks of the OpenStack Foundation, in the United States and other countries and are used with the OpenStack Foundation's permission. We are not affiliated with, endorsed or sponsored by the OpenStack Foundation, or the OpenStack community.

All other trademarks are the property of their respective owners.

Abstract

This guide provides procedures for installing, configuring, and using the Bare Metal service in the overcloud of a Red Hat OpenStack Platform environment.

Table of Contents

| | |
|--|-----------|
| PREFACE | 3 |
| CHAPTER 1. ABOUT THE BARE METAL SERVICE | 4 |
| CHAPTER 2. PLANNING FOR BARE METAL PROVISIONING | 6 |
| 2.1. INSTALLATION ASSUMPTIONS | 6 |
| 2.2. HARDWARE REQUIREMENTS | 6 |
| 2.3. NETWORKING REQUIREMENTS | 6 |
| 2.3.1. The Default Bare Metal Network | 7 |
| CHAPTER 3. DEPLOYING AN OVERCLOUD WITH THE BARE METAL SERVICE | 9 |
| 3.1. CREATING THE IRONIC TEMPLATE | 9 |
| 3.2. NETWORK CONFIGURATION | 9 |
| 3.3. EXAMPLE TEMPLATES | 10 |
| 3.4. DEPLOYING THE OVERCLOUD | 10 |
| 3.5. TESTING THE BARE METAL SERVICE | 11 |
| CHAPTER 4. CONFIGURING FOR THE BARE METAL SERVICE AFTER DEPLOYMENT | 12 |
| 4.1. CONFIGURING OPENSTACK NETWORKING | 12 |
| 4.2. CREATING THE BARE METAL FLAVOR | 13 |
| 4.3. CREATING THE BARE METAL IMAGES | 14 |
| 4.3.1. Preparing the Deploy Images | 14 |
| 4.3.2. Preparing the User Image | 15 |
| 4.4. ADDING PHYSICAL MACHINES AS BARE METAL NODES | 16 |
| 4.4.1. Enrolling a Bare Metal Node With an Inventory File | 16 |
| 4.4.2. Enrolling a Bare Metal Node Manually | 17 |
| 4.5. USING HOST AGGREGATES TO SEPARATE PHYSICAL AND VIRTUAL MACHINE PROVISIONING | 20 |
| CHAPTER 5. ADMINISTERING BARE METAL NODES | 22 |
| 5.1. LAUNCHING AN INSTANCE USING THE COMMAND LINE INTERFACE | 22 |
| 5.2. LAUNCH AN INSTANCE USING THE DASHBOARD | 22 |
| CHAPTER 6. TROUBLESHOOTING THE BARE METAL SERVICE | 24 |
| 6.1. PXE BOOT ERRORS | 24 |
| 6.2. LOGIN ERRORS AFTER THE BARE METAL NODE BOOTS | 25 |
| 6.3. THE BARE METAL SERVICE IS NOT GETTING THE RIGHT HOSTNAME | 26 |
| 6.4. INVALID OPENSTACK IDENTITY SERVICE CREDENTIALS WHEN EXECUTING BARE METAL SERVICE COMMANDS | 26 |
| 6.5. HARDWARE ENROLLMENT | 26 |
| 6.6. NO VALID HOST ERRORS | 26 |
| APPENDIX A. BARE METAL DRIVERS | 28 |
| A.1. INTELLIGENT PLATFORM MANAGEMENT INTERFACE (IPMI) | 28 |
| A.2. DELL REMOTE ACCESS CONTROLLER (DRAC) | 28 |
| A.3. INTEGRATED REMOTE MANAGEMENT CONTROLLER (IRMC) | 28 |
| A.4. INTEGRATED LIGHTS-OUT (ILO) | 29 |
| A.5. SSH AND VIRSH | 29 |

PREFACE

This document provides instructions for installing and configuring the Bare Metal service (ironic) in the overcloud, and using the service to provision and manage physical machines for end users.

The Bare Metal service components are also used by the Red Hat OpenStack Platform director, as part of the undercloud, to provision and manage the bare metal nodes that make up the OpenStack environment (the overcloud). For information on how the director uses the Bare Metal service, see [Director Installation and Usage](#).

CHAPTER 1. ABOUT THE BARE METAL SERVICE

The OpenStack Bare Metal service (ironic) provides the components required to provision and manage physical machines for end users. The Bare Metal service in the overcloud interacts with the following OpenStack services:

- OpenStack Compute (nova) provides scheduling, tenant quotas, IP assignment, and a user-facing API for virtual machine instance management, while the Bare Metal service provides the administrative API for hardware management.
- OpenStack Identity (keystone) provides request authentication and assists the Bare Metal service in locating other OpenStack services.
- OpenStack Image service (glance) manages images and image metadata.
- OpenStack Networking (neutron) provides DHCP and network configuration.
- OpenStack Object Storage (swift) is used by certain drivers to expose temporary URLs to images.

The Bare Metal service uses iPXE to provision physical machines. The following diagram outlines how the OpenStack services interact during the provisioning process when a user launches a new machine with the default drivers.

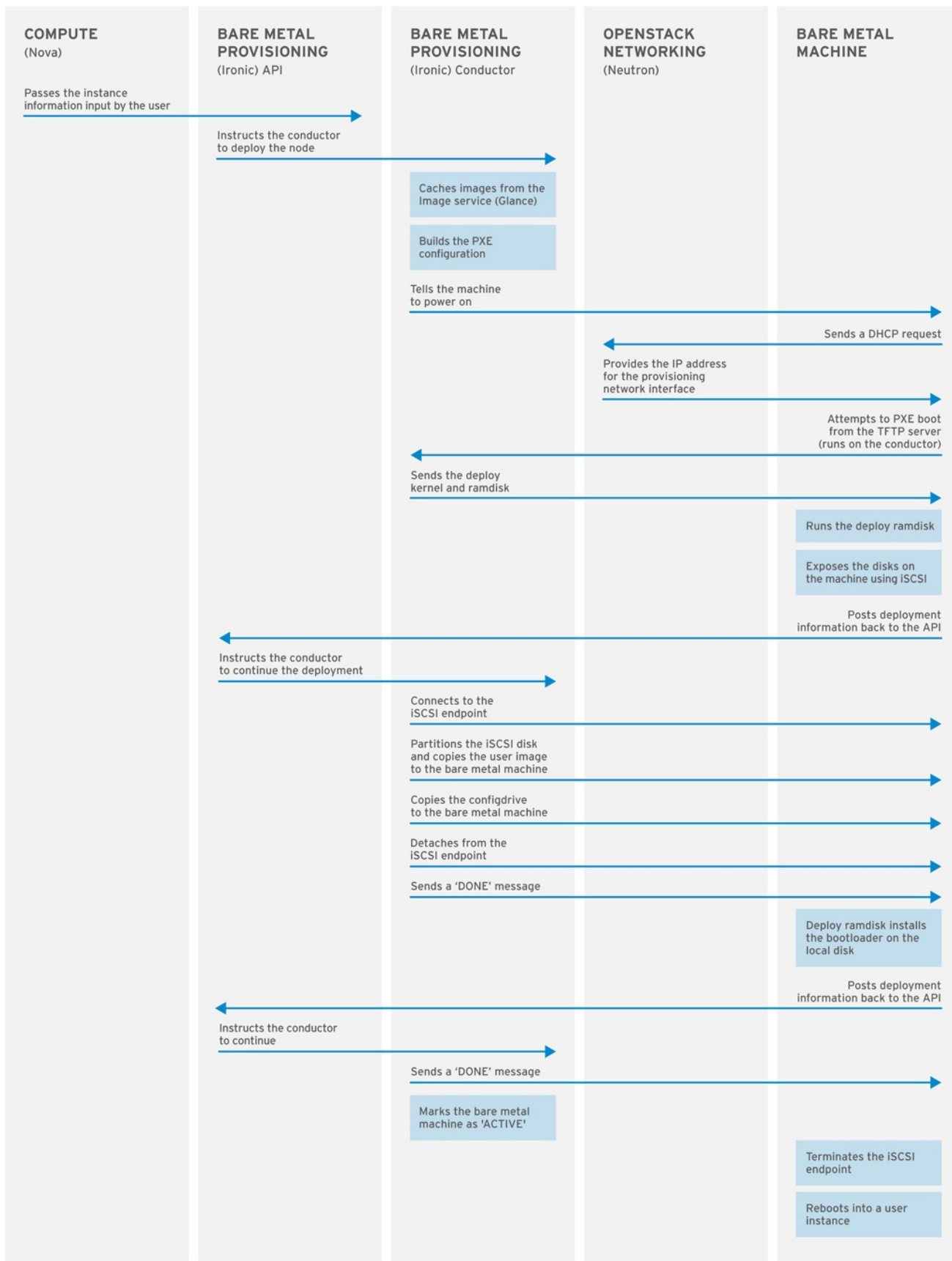

OPENSTACK_377593_1215

CHAPTER 2. PLANNING FOR BARE METAL PROVISIONING

This chapter outlines the requirements for setting up the Bare Metal service, including installation assumptions, hardware requirements, and networking requirements.

2.1. INSTALLATION ASSUMPTIONS

This guide assumes you have installed the director on the undercloud node, and are ready to install the Bare Metal service along with the rest of the overcloud. For more information on installing the director, see [Installing the Undercloud](#).

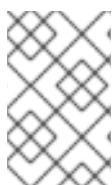

NOTE

The Bare Metal service in the overcloud is designed for a trusted tenant environment, as the bare metal nodes can access the control plane network of your OpenStack installation.

2.2. HARDWARE REQUIREMENTS

Overcloud Requirements

The hardware requirements for an overcloud with the Bare Metal service are the same as for the standard overcloud. For more information, see [Overcloud Requirements](#) in the *Director Installation and Usage* guide.

Bare Metal Machine Requirements

The hardware requirements for bare metal machines that will be provisioned vary depending on the operating system you are installing. For Red Hat Enterprise Linux 7, see the [Red Hat Enterprise Linux 7 Installation Guide](#). For Red Hat Enterprise Linux 6, see the [Red Hat Enterprise Linux 6 Installation Guide](#).

All bare metal machines to be provisioned require the following:

- A NIC to connect to the bare metal network.
- A power management interface (for example, IPMI) connected to a network reachable from the ironic-conductor service. If you are using the SSH driver for testing purposes, this is not required. By default, ironic-conductor runs on all of the controller nodes.
- PXE boot on the bare metal network. Disable PXE boot on all other NICs in the deployment.

2.3. NETWORKING REQUIREMENTS

The bare metal network:

This is a private network that the Bare Metal service uses for:

- The provisioning and management of bare metal machines on the overcloud.
- Cleaning bare metal nodes before and between deployments.
- Tenant access to the bare metal nodes.

The bare metal network provides DHCP and PXE boot functions to discover bare metal systems. This network must use a native VLAN on a trunked interface so that the Bare Metal service can serve PXE boot and DHCP requests.

The bare metal network must reach the control plane network:

The bare metal network must be routed to the control plane network. If you define an isolated bare metal network, the bare metal nodes will not be able to PXE boot.



NOTE

The Bare Metal service in the overcloud is designed for a trusted tenant environment, as the bare metal nodes have direct access to the control plane network of your OpenStack installation.

Network tagging:

- The control plane network (the director's provisioning network) is always untagged.
- The bare metal network must be untagged for provisioning, and must also have access to the Ironic API.
- Other networks may be tagged.

Overcloud controllers:

The controller nodes with the Bare Metal service must have access to the bare metal network.

Bare metal nodes:

The NIC which the bare metal node is configured to PXE-boot from must have access to the bare metal network.

2.3.1. The Default Bare Metal Network

In this architecture, the bare metal network is separated from the control plane network. The bare metal network also acts as the tenant network.

- The bare metal network is created by the OpenStack operator. This network requires a route to the director's provisioning network.
- Ironic users have access to the public OpenStack APIs, and to the bare metal network. Since the Bare metal network is routed to the director's provisioning network, users also have indirect access to the control plane.
- Ironic uses the bare metal network for node cleaning.

Default bare metal network architecture diagram

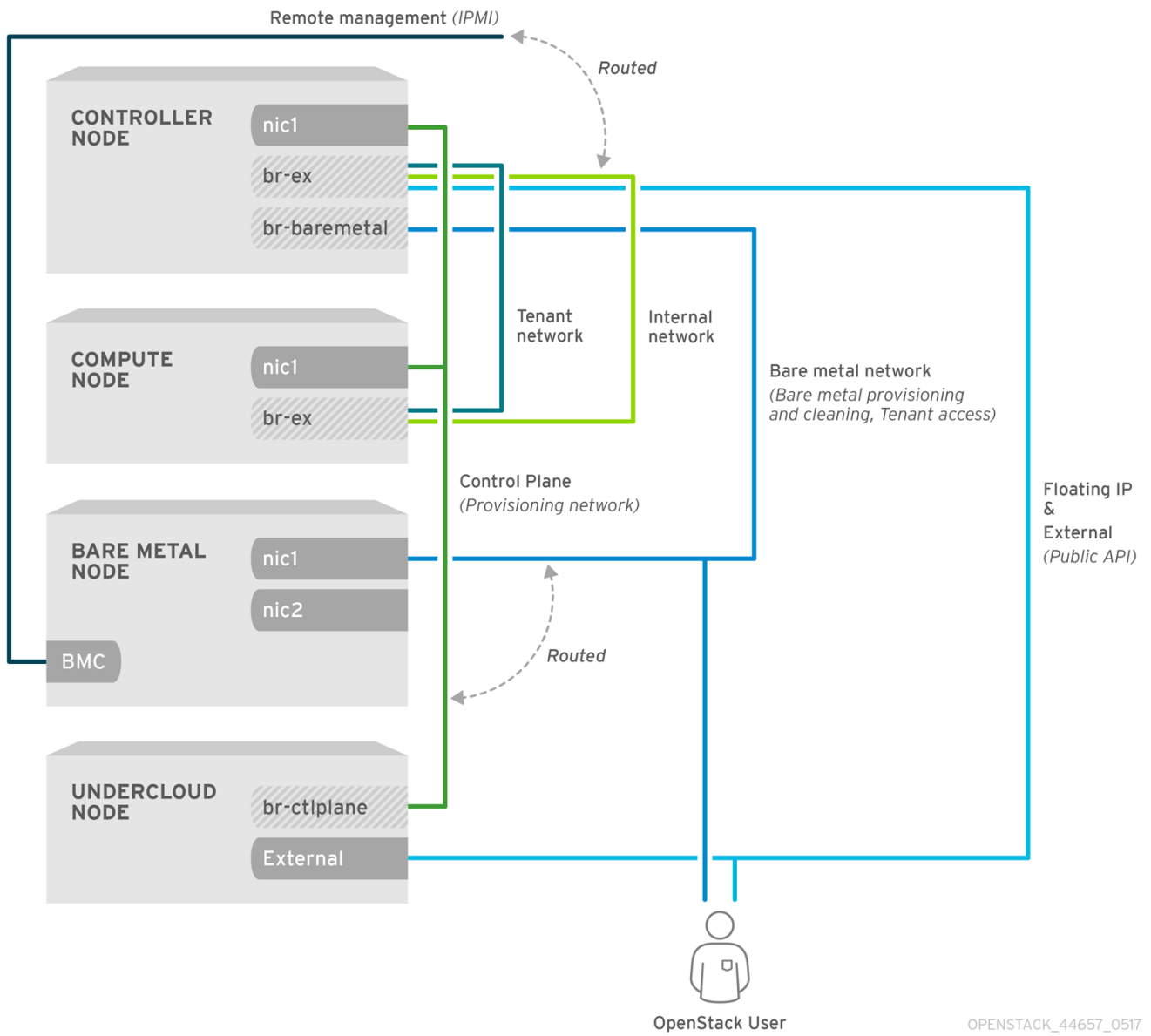

OPENSTACK_44657_0517

CHAPTER 3. DEPLOYING AN OVERCLOUD WITH THE BARE METAL SERVICE

For full details about overcloud deployment with the director, see [Director Installation and Usage](#). This chapter only covers deployment steps specific to ironic.

3.1. CREATING THE IRONIC TEMPLATE

Use an environment file to deploy the overcloud with the Bare Metal service enabled. A template is located on the director node at `/usr/share/openstack-tripleo-heat-templates/environments/services/ironic.yaml`.

Filling in the template

Additional configuration can be specified either in the provided template or in an additional yaml file, for example `~/templates/ironic.yaml`.

- For a hybrid deployment with both bare metal and virtual instances, you must add **AggregateInstanceExtraSpecsFilter** to the list of **NovaSchedulerDefaultFilters**. If you have not set **NovaSchedulerDefaultFilters** anywhere, you can do so in `ironic.yaml`. For an example, see [Section 3.3, "Example Templates"](#).



NOTE

If you are using SR-IOV, `NovaSchedulerDefaultFilters` is already set in `tripleo-heat-templates/environments/neutron-sriov.yaml`. Append **AggregateInstanceExtraSpecsFilter** to this list.

- The type of cleaning that occurs before and between deployments is set by **IronicCleaningDiskErase**. By default, this is set to 'full' by `puppet/services/ironic-conductor.yaml`. Setting this to 'metadata' can substantially speed up the process, as it only cleans the partition table, however, since the deployment will be less secure in multi-tenant environment, you should only do this in a trusted tenant environment.
- You can add drivers with the **IronicEnabledDrivers** parameter. By default, `pxe_ipmitool`, `pxe_drac` and `pxe_ilo` are enabled.

For a full list of configuration parameters, see the section [Bare Metal](#) in the Overcloud Parameters guide.

3.2. NETWORK CONFIGURATION

Create a bridge called **br-baremetal** for ironic to use. You can specify this in an additional template:

`~/templates/network-environment.yaml`

```
parameter_defaults:
  NeutronBridgeMappings: datacentre:br-ex,baremetal:br-baremetal
  NeutronFlatNetworks: datacentre,baremetal
```

You can either configure this bridge in the provisioning network (control plane) of the controllers, so you can reuse this network as the bare metal network, or add a dedicated network. The configuration requirements are the same, however the bare metal network cannot be VLAN-tagged, as it is used for provisioning.

```
~/templates/nic-configs/controller.yaml
```

```
network_config:
-
  type: ovs_bridge
  name: br-baremetal
  use_dhcp: false
  members:
-
  type: interface
  name: eth1
```

3.3. EXAMPLE TEMPLATES

The following is an example template file. This file may not meet the requirements of your environment. Before using this example, make sure it does not interfere with any existing configuration in your environment.

```
~/templates/ironic.yaml
```

```
parameter_defaults:

  NovaSchedulerDefaultFilters:
  - RetryFilter
  - AggregateInstanceExtraSpecsFilter
  - AvailabilityZoneFilter
  - RamFilter
  - DiskFilter
  - ComputeFilter
  - ComputeCapabilitiesFilter
  - ImagePropertiesFilter

  IronicCleaningDiskErase: metadata
```

In this example:

- The **AggregateInstanceExtraSpecsFilter** allows both virtual and bare metal instances, for a hybrid deployment.
- Disk cleaning that is done before and between deployments only erases the partition table (metadata).

3.4. DEPLOYING THE OVERCLOUD

To enable the Bare Metal service, include your ironic environment files with **-e** when deploying or redeploying the overcloud, along with the rest of your overcloud configuration.

For example:

```
$ openstack overcloud deploy \
--templates \
-e ~/templates/node-info.yaml \
-e /usr/share/openstack-tripleo-heat-templates/environments/network-isolation.yaml \
```

```
-e ~/templates/network-environment.yaml \  
-e /usr/share/openstack-tripleo-heat-templates/environments/services/ironic.yaml \  
-e ~/templates/ironic.yaml \  

```

For more information about deploying the overcloud, see [Creating the Overcloud with the CLI Tools](#) and [Including Environment Files in Overcloud Creation](#) .

3.5. TESTING THE BARE METAL SERVICE

You can use the OpenStack Integration Test Suite to validate your Red Hat OpenStack deployment. For more information, see the [OpenStack Integration Test Suite Guide](#) .

Additional Ways to Verify the Bare Metal Service:

1. Set up the shell to access Identity as the administrative user:

```
$ source ~/overcloudrc
```

2. Check that the **nova-compute** service is running on the controller nodes:

```
$ openstack compute service list -c Binary -c Host -c Status
```

3. If you have changed the default ironic drivers, make sure the required drivers are enabled:

```
$ openstack baremetal driver list
```

4. Ensure that the ironic endpoints are listed:

```
$ openstack catalog list
```

CHAPTER 4. CONFIGURING FOR THE BARE METAL SERVICE AFTER DEPLOYMENT

This section describes the steps necessary to configure your overcloud after deployment.

4.1. CONFIGURING OPENSTACK NETWORKING

Configure OpenStack Networking to communicate with the Bare Metal service for DHCP, PXE boot, and other requirements. The procedure below configures OpenStack Networking for a single, flat network use case for provisioning onto bare metal. The configuration uses the ML2 plug-in and the Open vSwitch agent. Only **flat** networks are supported.

This procedure creates a bridge using the bare metal network interface, and drops any remote connections.

All steps in the following procedure must be performed on the server hosting OpenStack Networking, while logged in as the **root** user.

Configuring OpenStack Networking to Communicate with the Bare Metal Service

1. Set up the shell to access Identity as the administrative user:

```
$ source ~/overcloudrc
```

2. Create the flat network over which to provision bare metal instances:

```
$ openstack network create \
  --provider-network-type flat \
  --provider-physical-network baremetal \
  --share NETWORK_NAME
```

Replace *NETWORK_NAME* with a name for this network. The name of the physical network over which the virtual network is implemented, (in this case **baremetal**), was set earlier in `~/templates/network-environment.yaml`, with the parameter **NeutronBridgeMappings**.

3. Create the subnet on the flat network:

```
$ openstack subnet create \
  --network NETWORK_NAME \
  --subnet-range NETWORK_CIDR \
  --ip-version 4 \
  --gateway GATEWAY_IP \
  --allocation-pool start=START_IP,end=END_IP \
  --dhcp SUBNET_NAME
```

Replace the following values:

- Replace *SUBNET_NAME* with a name for the subnet.
- Replace *NETWORK_NAME* with the name of the provisioning network you created in the previous step.
- Replace *NETWORK_CIDR* with the Classless Inter-Domain Routing (CIDR) representation of the block of IP addresses the subnet represents. The block of IP addresses specified by

the range started by *START_IP* and ended by *END_IP* must fall within the block of IP addresses specified by *NETWORK_CIDR*.

- Replace *GATEWAY_IP* with the IP address or host name of the router interface that will act as the gateway for the new subnet. This address must be within the block of IP addresses specified by *NETWORK_CIDR*, but outside of the block of IP addresses specified by the range started by *START_IP* and ended by *END_IP*.
 - Replace *START_IP* with the IP address that denotes the start of the range of IP addresses within the new subnet from which floating IP addresses will be allocated.
 - Replace *END_IP* with the IP address that denotes the end of the range of IP addresses within the new subnet from which floating IP addresses will be allocated.
4. Attach the network and subnet to the router to ensure the metadata requests are served by the OpenStack Networking service.

```
$ openstack router create ROUTER_NAME
```

Replace **ROUTER_NAME** with a name for the router.

5. Add the Bare Metal subnet to this router:

```
$ openstack router add subnet ROUTER_NAME BAREMETAL_SUBNET
```

Replace *ROUTER_NAME* with the name of your router and *BAREMETAL_SUBNET* with the ID or subnet name that you previously created. This allows the metadata requests from **cloud-init** to be served and the node configured.

6. Configure cleaning by providing the provider network UUID on the controller running the Bare Metal Service:

```
~/templates/ironic.yaml
```

```
parameter_defaults:
  ControllerExtraConfig:
    ironic::conductor::cleaning_network_uuid: UUID
```

Replace **UUID** with the UUID of the bare metal network created in the previous steps.

You can find the UUID using **openstack network show**:

```
openstack network show NETWORK_NAME -f value -c id
```

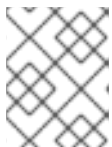

NOTE

This configuration must be done after the initial overcloud deployment, because the UUID for the network isn't available beforehand.

7. Apply the changes by redeploying the overcloud with the **openstack overcloud deploy** command as described in [Section 3.4, "Deploying the Overcloud"](#).

4.2. CREATING THE BARE METAL FLAVOR

You need to create a flavor to use as a part of the deployment. The specifications (memory, CPU, and disk) of this flavor must be equal to or less than what your bare metal node provides.

1. Set up the shell to access Identity as the administrative user:

```
$ source ~/overcloudrc
```

2. List existing flavors:

```
$ openstack flavor list
```

3. Create a new flavor for the Bare Metal service:

```
$ openstack flavor create \  
  --id auto --ram RAM \  
  --vcpus VCPU --disk DISK \  
  --property baremetal=true \  
  --public baremetal
```

Replace **RAM** with the amount of memory, **VCPU** with the number of vCPUs and **DISK** with the disk storage value. The property **baremetal** is used to distinguish bare metal from virtual instances.

4. Verify that the new flavor is created with the respective values:

```
$ openstack flavor list
```

4.3. CREATING THE BARE METAL IMAGES

The deployment requires two sets of images:

- The **deploy image** is used by the Bare Metal service to boot the bare metal node and copy a user image onto the bare metal node. The deploy image consists of the **kernel** image and the **ramdisk** image.
- The **user image** is the image deployed onto the bare metal node. The user image also has a **kernel** image and **ramdisk** image, but additionally, the user image contains a **main** image. The main image is either a root partition, or a whole-disk image.
 - A **whole-disk image** is an image that contains the partition table and boot loader. The Bare Metal service does not control the subsequent reboot of a node deployed with a whole-disk image as the node supports localboot.
 - A **root partition image** only contains the root partition of the operating system. If using a root partition, after the deploy image is loaded into the Image service, you can set the deploy image as the node's boot image in the node's properties. A subsequent reboot of the node uses netboot to pull down the user image.

The examples in this section use a root partition image to provision bare metal nodes.

4.3.1. Preparing the Deploy Images

You do not have to create the deploy image as it was already used when the overcloud was deployed by the undercloud. The deploy image consists of two images - the kernel image and the ramdisk image as follows:

```
ironic-python-agent.kernel
ironic-python-agent.initramfs
```

These images are often in the home directory, unless you have deleted them, or unpacked them elsewhere. If they are not in the home directory, and you still have the **rhosp-director-images-ipa** package installed, these images will be in the **/usr/share/rhosp-director-images/ironic-python-agent*.tar** file.

Extract the images and upload them to the Image service:

```
$ openstack image create \
  --container-format aki \
  --disk-format aki \
  --public \
  --file ./ironic-python-agent.kernel bm-deploy-kernel
$ openstack image create \
  --container-format ari \
  --disk-format ari \
  --public \
  --file ./ironic-python-agent.initramfs bm-deploy-ramdisk
```

4.3.2. Preparing the User Image

The final image that you need is the user image that will be deployed on the bare metal node. User images also have a kernel and ramdisk, along with a main image.

1. Download the Red Hat Enterprise Linux KVM guest image from the [Customer Portal](#) (requires login).
2. Define `DIB_LOCAL_IMAGE` as the downloaded image:

```
$ export DIB_LOCAL_IMAGE=rhel-server-7.4-beta-1-x86_64-kvm.qcow2
```

3. Create the user images using the **diskimage-builder** tool:

```
$ disk-image-create rhel7 baremetal -o rhel-image
```

This extracts the kernel as **rhel-image.vmlinuz** and initial ramdisk as **rhel-image.initrd**.

4. Upload the images to the Image service:

```
$ KERNEL_ID=$(openstack image create \
  --file rhel-image.vmlinuz --public \
  --container-format aki --disk-format aki \
  -f value -c id rhel-image.vmlinuz)
$ RAMDISK_ID=$(openstack image create \
  --file rhel-image.initrd --public \
  --container-format ari --disk-format ari \
  -f value -c id rhel-image.initrd)
$ openstack image create \
```

```
--file rhel-image.qcow2 --public \
--container-format bare \
--disk-format qcow2 \
--property kernel_id=$KERNEL_ID \
--property ramdisk_id=$RAMDISK_ID \
rhel-image
```

4.4. ADDING PHYSICAL MACHINES AS BARE METAL NODES

There are two methods to enroll a bare metal node:

1. Prepare an inventory file with the node details, import the file into the Bare Metal service, then make the nodes available.
2. Register a physical machine as a bare metal node, then manually add its hardware details and create ports for each of its Ethernet MAC addresses. These steps can be performed on any node which has your `overcloudrc` file.

Both methods are detailed in this section.

After enrolling the physical machines, Compute is not immediately notified of new resources, because Compute's resource tracker synchronizes periodically. Changes will be visible after the next periodic task is run. This value, `scheduler_driver_task_period`, can be updated in `/etc/nova/nova.conf`. The default period is 60 seconds.

4.4.1. Enrolling a Bare Metal Node With an Inventory File

1. Create a file `overcloud-nodes.yaml`, including the node details. Multiple nodes can be enrolled with one file.

```
nodes:
  - name: node0
    driver: pxe_ipmitool
    driver_info:
      ipmi_address: <IPMI_IP>
      ipmi_username: <USER>
      ipmi_password: <PASSWORD>
    properties:
      cpus: <CPU_COUNT>
      cpu_arch: <CPU_ARCHITECTURE>
      memory_mb: <MEMORY>
      local_gb: <ROOT_DISK>
      root_device:
        serial: <SERIAL>
    ports:
      - address: <PXE_NIC_MAC>
```

Replace the following values:

- `<IPMI_IP>` with the IP address of the Bare Metal controller.
- `<USER>` with your username.
- `<PASSWORD>` with your password.

- **<CPU_COUNT>** with the number of CPUs.
 - **<CPU_ARCHITECTURE>** with the type of architecture of the CPUs.
 - **<MEMORY>** with the amount of memory in MiB.
 - **<ROOT_DISK>** with the size of the root disk in GiB.
 - **<MAC_ADDRESS>** with the MAC address of the NIC used to PXE boot.
You only need to include **root_device** if the machine has multiple disks. Replace **<SERIAL>** with the serial number of the disk you would like used for deployment.
2. Set up the shell to use Identity as the administrative user:

```
$ source ~/overcloudrc
```

3. Import the inventory file into ironic:

```
$ openstack baremetal create overcloud-nodes.yaml
```

4. The nodes are now in the **enroll** state. Make them available by specifying the deploy kernel and deploy ramdisk on each node:

```
$ openstack baremetal node set NODE_UUID \
  --driver-info deploy_kernel=KERNEL_UUID \
  --driver-info deploy_ramdisk=INITRAMFS_UUID
```

Replace the following values:

- Replace *NODE_UUID* with the unique identifier for the node. Alternatively, use the node's logical name.
- Replace *KERNEL_UUID* with the unique identifier for the **kernel** deploy image that was uploaded to the Image service. Find this value with:

```
$ openstack image show bm-deploy-kernel -f value -c id
```

- Replace *INITRAMFS_UUID* with the unique identifier for the **ramdisk** image that was uploaded to the Image service. Find this value with:

```
$ openstack image show bm-deploy-ramdisk -f value -c id
```

5. Check that the nodes were successfully enrolled:

```
$ openstack baremetal node list
```

There may be a delay between enrolling a node and its state being shown.

4.4.2. Enrolling a Bare Metal Node Manually

1. Set up the shell to use Identity as the administrative user:

```
$ source ~/overcloudrc
```

2. Add a new node:

```
$ openstack baremetal node create --driver pxe_impitool --name NAME
```

To create a node you must specify the driver name. This example uses **pxe_impitool**. To use a different driver, you must enable it by setting the **IronicEnabledDrivers** parameter. For more information on supported drivers, see [Appendix A, Bare Metal Drivers](#).

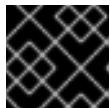

IMPORTANT

Note the unique identifier for the node.

3. Update the node driver information to allow the Bare Metal service to manage the node:

```
$ openstack baremetal node set NODE_UUID \
  --driver_info PROPERTY=VALUE \
  --driver_info PROPERTY=VALUE
```

Replace the following values:

- Replace *NODE_UUID* with the unique identifier for the node. Alternatively, use the node's logical name.
- Replace *PROPERTY* with a required property returned by the **ironic driver-properties** command.
- Replace *VALUE* with a valid value for that property.

4. Specify the deploy kernel and deploy ramdisk for the node driver:

```
$ openstack baremetal node set NODE_UUID \
  --driver-info deploy_kernel=KERNEL_UUID \
  --driver-info deploy_ramdisk=INITRAMFS_UUID
```

Replace the following values:

- Replace *NODE_UUID* with the unique identifier for the node. Alternatively, use the node's logical name.
- Replace *KERNEL_UUID* with the unique identifier for the **.kernel** image that was uploaded to the Image service.
- Replace *INITRAMFS_UUID* with the unique identifier for the **.initramfs** image that was uploaded to the Image service.

5. Update the node's properties to match the hardware specifications on the node:

```
$ openstack baremetal node set NODE_UUID \
  --property cpus=CPU \
  --property memory_mb=RAM_MB \
  --property local_gb=DISK_GB \
  --property cpu_arch=ARCH
```

Replace the following values:

- Replace *NODE_UUID* with the unique identifier for the node. Alternatively, use the node's logical name.
 - Replace *CPU* with the number of CPUs.
 - Replace *RAM_MB* with the RAM (in MB).
 - Replace *DISK_GB* with the disk size (in GB).
 - Replace *ARCH* with the architecture type.
6. OPTIONAL: Configure the node to reboot after initial deployment from a local boot loader installed on the node's disk, instead of using PXE from **ironic-conductor**. The local boot capability must also be set on the flavor used to provision the node. To enable local boot, the image used to deploy the node must contain **grub2**. Configure local boot:

```
$ openstack baremetal node set NODE_UUID \
  --property capabilities="boot_option:local"
```

Replace *NODE_UUID* with the unique identifier for the node. Alternatively, use the node's logical name.

7. Inform the Bare Metal service of the node's network card by creating a port with the MAC address of the NIC on the provisioning network:

```
$ openstack baremetal port create --node NODE_UUID MAC_ADDRESS
```

Replace *NODE_UUID* with the unique identifier for the node. Replace *MAC_ADDRESS* with the MAC address of the NIC used to PXE boot.

8. If you have multiple disks, set the root device hints. This informs the deploy ramdisk which disk it should use for deployment.

```
$ openstack baremetal node set NODE_UUID \
  --property root_device={"PROPERTY": "VALUE"}
```

Replace with the following values:

- Replace *NODE_UUID* with the unique identifier for the node. Alternatively, use the node's logical name.
- Replace *PROPERTY* and *VALUE* with details about the disk you want used for deployment, for example **root_device={'size': 128}**
The following properties are supported:
 - **model** (String): Device identifier.
 - **vendor** (String): Device vendor.
 - **serial** (String): Disk serial number.
 - **hctl** (String): Host:Channel:Target:Lun for SCSI.
 - **size** (Integer): Size of the device in GB.
 - **wwn** (String): Unique storage identifier.

- **wwn_with_extension** (String): Unique storage identifier with the vendor extension appended.
- **wwn_vendor_extension** (String): Unique vendor storage identifier.
- **rotational** (Boolean): True for a rotational device (HDD), otherwise false (SSD).
- **name** (String): The name of the device, for example: /dev/sdb1 Only use this for devices with persistent names.

**NOTE**

If you specify more than one property, the device must match all of those properties.

9. Validate the node's setup:

```
$ openstack baremetal node validate NODE_UUID
+-----+-----+-----+
| Interface | Result | Reason |
+-----+-----+-----+
| boot      | False  | Cannot validate image information for node |
|           |         | a02178db-1550-4244-a2b7-d7035c743a9b |
|           |         | because one or more parameters are missing |
|           |         | from its instance_info. Missing are: |
|           |         | ['ramdisk', 'kernel', 'image_source'] |
| console   | None   | not supported |
| deploy    | False  | Cannot validate image information for node |
|           |         | a02178db-1550-4244-a2b7-d7035c743a9b |
|           |         | because one or more parameters are missing |
|           |         | from its instance_info. Missing are: |
|           |         | ['ramdisk', 'kernel', 'image_source'] |
| inspect   | None   | not supported |
| management | True   | |
| network   | True   | |
| power     | True   | |
| raid      | True   | |
| storage   | True   | |
+-----+-----+-----+
```

Replace *NODE_UUID* with the unique identifier for the node. Alternatively, use the node's logical name. The output of the command above should report either **True** or **None** for each interface. Interfaces marked **None** are those that you have not configured, or those that are not supported for your driver.

**NOTE**

Interfaces may fail validation due to missing 'ramdisk', 'kernel', and 'image_source' parameters. This result is fine, because the Compute service populates those missing parameters at the beginning of the deployment process.

4.5. USING HOST AGGREGATES TO SEPARATE PHYSICAL AND VIRTUAL MACHINE PROVISIONING

OpenStack Compute uses host aggregates to partition availability zones, and group together nodes with specific shared properties. When an instance is provisioned, Compute's scheduler compares properties on the flavor with the properties assigned to host aggregates, and ensures that the instance is provisioned in the correct aggregate and on the correct host: either on a physical machine or as a virtual machine.

The procedure below describes how to do the following:

- Add the property **baremetal** to your flavors, setting it to either **true** or **false**.
- Create separate host aggregates for bare metal hosts and compute nodes with a matching **baremetal** property. Nodes grouped into an aggregate inherit this property.

Creating a Host Aggregate

1. Set the **baremetal** property to **true** on the baremetal flavor.

```
$ openstack flavor set baremetal --property baremetal=true
```

2. Set the **baremetal** property to **false** on the flavors used for virtual instances.

```
$ openstack flavor set FLAVOR_NAME --property baremetal=false
```

3. Create a host aggregate called **baremetal-hosts**:

```
$ openstack aggregate create --property baremetal=true baremetal-hosts
```

4. Add each controller node to the **baremetal-hosts** aggregate:

```
$ openstack aggregate add host baremetal-hosts HOSTNAME
```



NOTE

If you have created a composable role with the **Novalronic** service, add all the nodes with this service to the **baremetal-hosts** aggregate. By default, only the controller nodes have the **Novalronic** service.

5. Create a host aggregate called **virtual-hosts**:

```
$ openstack aggregate create --property baremetal=false virtual-hosts
```

6. Add each compute node to the **virtual-hosts** aggregate:

```
$ openstack aggregate add host virtual-hosts HOSTNAME
```

7. If you did not add the following Compute filter scheduler when deploying the overcloud, add it now to the existing list under **scheduler_default_filters** in `/etc/nova/nova.conf`:

```
AggregateInstanceExtraSpecsFilter
```

CHAPTER 5. ADMINISTERING BARE METAL NODES

This chapter describes how to provision a physical machine on an enrolled bare metal node. Instances can be launched either from the command line or from the OpenStack dashboard.

5.1. LAUNCHING AN INSTANCE USING THE COMMAND LINE INTERFACE

Use the `openstack` command line interface to deploy a bare metal instance.

Deploying an Instance on the Command Line

1. Set up the shell to access Identity as the administrative user:

```
$ source ~/overcloudrc
```

2. Deploy the instance:

```
$ openstack server create \  
  --nic net-id=NETWORK_UUID \  
  --flavor baremetal \  
  --image IMAGE_UUID \  
  INSTANCE_NAME
```

Replace the following values:

- Replace *NETWORK_UUID* with the unique identifier for the network that was created for use with the Bare Metal service.
 - Replace *IMAGE_UUID* with the unique identifier for the disk image that was uploaded to the Image service.
 - Replace *INSTANCE_NAME* with a name for the bare metal instance.
3. Check the status of the instance:

```
$ openstack server list --name INSTANCE_NAME
```

5.2. LAUNCH AN INSTANCE USING THE DASHBOARD

Use the dashboard graphical user interface to deploy a bare metal instance.

Deploying an Instance in the Dashboard

1. Log in to the dashboard at `http[s]://DASHBOARD_IP/dashboard`.
2. Click **Project > Compute > Instances**
3. Click **Launch Instance**.
 - In the **Details** tab, specify the **Instance Name** and select **1** for **Count**.

- In the **Source** tab, select an **Image** from **Select Boot Source**, then click the **+** (plus) symbol to select an operating system disk image. The chosen image will move to **Allocated**.
 - In the **Flavor** tab, select **baremetal**.
 - In the **Networks** tab, use the **+** (plus) and **-** (minus) buttons to move required networks from **Available** to **Allocated**. Ensure that the shared network created for the Bare Metal service is selected here.
4. Click **Launch Instance**.

CHAPTER 6. TROUBLESHOOTING THE BARE METAL SERVICE

The following sections contain information and steps that may be useful for diagnosing issues in a setup with the Bare Metal service enabled.

6.1. PXE BOOT ERRORS

Permission Denied Errors

If you are getting a permission denied error on the console of your Bare Metal service node, make sure you have applied the appropriate SELinux context to the `/httpboot` and `/tftpboot` directories as follows:

```
# semanage fcontext -a -t httpd_sys_content_t "/httpboot(/.*)?"
# restorecon -r -v /httpboot
# semanage fcontext -a -t tftpd_t "/tftpboot(/.*)?"
# restorecon -r -v /tftpboot
```

Boot Process Freezes at `/pxelinux.cfg/XX-XX-XX-XX-XX-XX`

On the console of your node, if it looks like you are getting an IP address and then the process stops as shown below:

```
overcloud-baremetal-node on QEMU/KVM
File Virtual Machine View Send Key
[Icons]

IPXE (http://ipxe.org) 00:0C:00 CF00 PCI2.10 PnP PMM BFF95EC0 BFEF5EC0 CF00

Booting from ROM...
IPXE (PCI 00:03:0) starting execution...ok
IPXE initialising devices...ok

IPXE 1.0.0+ (dc795b9f) -- Open Source Network Boot Firmware -- http://ipxe.org
Features: DNS HTTP iSCSI TFTP AoE ELF MBOOT PXE bzImage Menu PXEXT

net0: 52:54:00:fa:19:88 using virtio-net on PCI00:03:0 (open)
[Link:up, TX:0 TXE:0 RX:0 RXE:0]
Configuring (net0 52:54:00:fa:19:88)..... ok
net0: 192.168.200.20/255.255.255.0 gw 192.168.200.9
Next server: 192.168.200.2
Filename: http://192.168.200.2:8088/boot.ipxe
http://192.168.200.2:8088/boot.ipxe... ok
Attempting to boot from MAC 52-54-00-fa-19-88
/pxelinux.cfg/52-54-00-fa-19-88... ok
-
```

This indicates that you might be using the wrong PXE boot template in your `ironic.conf` file.

```
$ grep ^pxe_config_template ironic.conf
pxe_config_template=$pybasedir/drivers/modules/ipxe_config.template
```

The default template is **pxe_config.template**, so it is easy to miss the *i* to turn this into **ipxe_config.template**.

6.2. LOGIN ERRORS AFTER THE BARE METAL NODE BOOTS

When you try to log in at the login prompt on the console of the node with the **root** password that you set in the configurations steps, but are not able to, it indicates you are not booted in to the deployed image. You are probably stuck in the **deploy-kernel/deploy-ramdisk** image and the system has yet to get the correct image.

To fix this issue, verify the PXE Boot Configuration file in the **/httpboot/pxelinux.cfg/MAC_ADDRESS** on the Compute or Bare Metal service node and ensure that all the IP addresses listed in this file correspond to IP addresses on the Bare Metal network.



NOTE

The only network the Bare Metal service node knows about is the Bare Metal network. If one of the endpoints is not on the network, the endpoint will not be able to reach the Bare Metal service node as a part of the boot process.

For example, the kernel line in your file is as follows:

```
kernel http://192.168.200.2:8088/5a6cdbe3-2c90-4a90-b3c6-85b449b30512/deploy_kernel selinux=0
disk=cciss/c0d0,sda,hda,vda iscsi_target_iqn=iqn.2008-10.org.openstack:5a6cdbe3-2c90-4a90-b3c6-
85b449b30512 deployment_id=5a6cdbe3-2c90-4a90-b3c6-85b449b30512
deployment_key=VWDYDVVEFCQJNOSTO9R67HKUXUGP77CK
ironic_api_url=http://192.168.200.2:6385 troubleshoot=0 text nofb nomodeset vga=normal
boot_option=netboot ip=${ip}:${next-server}:${gateway}:${netmask} BOOTIF=${mac} ipa-api-
url=http://192.168.200.2:6385 ipa-driver-name=pxe_ssh boot_mode=bios initrd=deploy_ramdisk
coreos.configdrive=0 || goto deploy
```

| Value in the above example kernel line | Corresponding information |
|--|--|
| http://192.168.200.2:8088 | Parameter http_url in /etc/ironic/ironic.conf file. This IP address must be on the Bare Metal network. |
| 5a6cdbe3-2c90-4a90-b3c6-85b449b30512 | UUID of the baremetal node in ironic node-list . |
| deploy_kernel | This is the deploy kernel image in the Image service that is copied down as /httpboot/<NODE_UUID>/deploy_kernel . |

| Value in the above example kernel line | Corresponding information |
|--|--|
| http://192.168.200.2:6385 | Parameter api_url in /etc/ironic/ironic.conf file. This IP address must be on the Bare Metal network. |
| pxe_ssh | The IPMI Driver in use by the Bare Metal service for this node. |
| deploy_ramdisk | This is the deploy ramdisk image in the Image service that is copied down as /httpboot/<NODE_UUID>/deploy_ramdisk . |

If a value does not correspond between the **/httpboot/pxelinux.cfg/MAC_ADDRESS** and the **ironic.conf** file:

1. Update the value in the **ironic.conf** file
2. Restart the Bare Metal service
3. Re-deploy the bare metal instance

6.3. THE BARE METAL SERVICE IS NOT GETTING THE RIGHT HOSTNAME

If the Bare Metal service is not getting the right hostname, it means that **cloud-init** is failing. To fix this, connect the Bare Metal subnet to a router in the OpenStack Networking service. The requests to the meta-data agent should now be routed correctly.

6.4. INVALID OPENSTACK IDENTITY SERVICE CREDENTIALS WHEN EXECUTING BARE METAL SERVICE COMMANDS

If you are having trouble authenticating to the Identity service, check the **identity_uri** parameter in the **ironic.conf** file and make sure you remove the **/v2.0** from the **keystone** AdminURL. For example, **identity_uri** should be set to **http://IP:PORT**.

6.5. HARDWARE ENROLLMENT

Issues with enrolled hardware can be caused by incorrect node registration details. Ensure that property names and values have been entered correctly. Incorrect or mistyped property names will be successfully added to the node's details, but will be ignored.

Update a node's details. This example updates the amount of memory the node is registered to use to 2 GB:

```
$ openstack baremetal node set --property memory_mb=2048 NODE_UUID
```

6.6. NO VALID HOST ERRORS

If the Compute scheduler cannot find a suitable Bare Metal node on which to boot an instance, a

NoValidHost error can be seen in `/var/log/nova/nova-conductor.log` or immediately upon launch failure in the dashboard. This is usually caused by a mismatch between the resources Compute expects and the resources the Bare Metal node provides.

1. Check the hypervisor resources that are available:

```
$ openstack hypervisor stats show
```

The resources reported here should match the resources that the Bare Metal nodes provide.

2. Check that Compute recognizes the Bare Metal nodes as hypervisors:

```
$ openstack hypervisor list
```

The nodes, identified by UUID, should appear in the list.

3. Check the details for a Bare Metal node:

```
$ openstack baremetal node list
$ openstack baremetal node show NODE_UUID
```

Verify that the node's details match those reported by Compute.

4. Check that the selected flavor does not exceed the available resources of the Bare Metal nodes:

```
$ openstack flavor show FLAVOR_NAME
```

5. Check the output of **openstack baremetal node list** to ensure that Bare Metal nodes are not in maintenance mode. Remove maintenance mode if necessary:

```
$ openstack baremetal node maintenance unset NODE_UUID
```

6. Check the output of **openstack baremetal node list** to ensure that Bare Metal nodes are in an **available** state. Move the node to **available** if necessary:

```
$ openstack baremetal node provide NODE_UUID
```

APPENDIX A. BARE METAL DRIVERS

A bare metal node can be configured to use one of the drivers enabled in the Bare Metal service. Each driver is made up of a provisioning method and a power management type. Some drivers require additional configuration. Each driver described in this section uses PXE for provisioning; drivers are listed by their power management type.

You can add drivers with the **IronicEnabledDrivers** parameter in your **ironic.yaml** file. By default, **pxe_ipmitool**, **pxe_drac** and **pxe_ilo** are enabled.

For the full list of supported plug-ins and drivers, see [Component, Plug-In, and Driver Support in Red Hat OpenStack Platform](#).

A.1. INTELLIGENT PLATFORM MANAGEMENT INTERFACE (IPMI)

IPMI is an interface that provides out-of-band remote management features, including power management and server monitoring. To use this power management type, all Bare Metal service nodes require an IPMI that is connected to the shared Bare Metal network. Enable the **pxe_ipmitool** driver, and set the following information in the node's **driver_info**:

- **ipmi_address** - The IP address of the IPMI NIC.
- **ipmi_username** - The IPMI user name.
- **ipmi_password** - The IPMI password.

A.2. DELL REMOTE ACCESS CONTROLLER (DRAC)

DRAC is an interface that provides out-of-band remote management features, including power management and server monitoring. To use this power management type, all Bare Metal service nodes require a DRAC that is connected to the shared Bare Metal network. Enable the **pxe_drac** driver, and set the following information in the node's **driver_info**:

- **drac_address** - The IP address of the DRAC NIC.
- **drac_username** - The DRAC user name.
- **drac_password** - The DRAC password.

A.3. INTEGRATED REMOTE MANAGEMENT CONTROLLER (iRMC)

iRMC from Fujitsu is an interface that provides out-of-band remote management features including power management and server monitoring. To use this power management type on a Bare Metal service node, the node requires an iRMC interface that is connected to the shared Bare Metal network. Enable the **pxe_irmc** driver, and set the following information in the node's **driver_info**:

- **irmc_address** - The IP address of the iRMC interface NIC.
- **irmc_username** - The iRMC user name.
- **irmc_password** - The iRMC password.

To use IPMI to set the boot mode or SCCI to get sensor data, you must complete the following additional steps:

1. Enable the sensor method in *ironic.conf*:

```
$ openstack-config --set /etc/ironic/ironic.conf \
  irmc sensor_method METHOD
```

Replace *METHOD* with **scci** or **ipmitool**.

2. If you enabled SCCI, install the **python-scciclient** package:

```
# yum install python-scciclient
```

3. Restart the Bare Metal conductor service:

```
# systemctl restart openstack-ironic-conductor.service
```



NOTE

To use the iRMC driver, iRMC S4 or higher is required.

A.4. INTEGRATED LIGHTS-OUT (ILO)

iLO from Hewlett-Packard is an interface that provides out-of-band remote management features including power management and server monitoring. To use this power management type, all Bare Metal nodes require an iLO interface that is connected to the shared Bare Metal network. Enable the **pxe_ilo** driver, and set the following information in the node's **driver_info**:

- **ilo_address** - The IP address of the iLO interface NIC.
- **ilo_username** - The iLO user name.
- **ilo_password** - The iLO password.

You must also install the **python-proliantutils** package and restart the Bare Metal conductor service:

```
# yum install python-proliantutils
# systemctl restart openstack-ironic-conductor.service
```

A.5. SSH AND VIRSH

The Bare Metal service can access a host that is running libvirt and use virtual machines as nodes. Virsh controls the power management of the nodes.

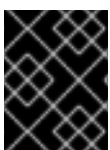

IMPORTANT

The SSH driver is for testing and evaluation purposes only. It is not recommended for Red Hat OpenStack Platform enterprise environments.

To use this power management type, the Bare Metal service must have SSH access to an account with full access to the libvirt environment on the host where the virtual nodes will be set up. Enable the **pxe_ssh** driver, and set the following information in the node's **driver_info**:

- **ssh_virt_type** - Set this option to **virsh**.

- **ssh_address** - The IP address of the virsh host.
- **ssh_username** - The SSH user name.
- **ssh_key_contents** - The contents of the SSH private key on the Bare Metal conductor node. The matching public key must be copied to the virsh host.